

WESTWOOD AFJROTC CADET GUIDE

2014-2015



This Guide Belongs To: _____

WESTWOOD HIGH SCHOOL TX-861ST AIR WARRIORS!

“Choices – Responsibilities – Accountability”

Major Phillip Sandlin - Senior Aerospace Science Instructor

Master Sergeant Mark Janik - Aerospace Science Instructor



AIR FORCE JROTC - TEXAS 861st

Westwood High School
12400 Mellow Meadow Drive
Austin, Texas 78750
PH: (512) 464-4096
FAX: (512)-464-4098



Email: phillip_sandlin@roundrockisd.org

2014 – 2015 School Year

Congratulations to each of you on your decision to participate in a nationally recognized and exceptional program. The Texas 861st Air Force Junior Reserve Officer Training Corps (AFJROTC) was established at Westwood High School in 1986 by an agreement between the Air Force, Round Rock Independent School District, and Westwood High School.

The AFJROTC curriculum includes instruction and training in aerospace science, leadership and wellness, in addition to supporting a variety of student-led teams and community service activities. The Senior Aerospace Science Instructor (SASI) officer position is filled by Major (Maj) Phillip S. Sandlin, USAF (Retired). Major Sandlin has held a multitude of enlisted and officer assignments during his 21+ years in the Air Force, in which many military operations were included (Operations Just Cause, Beirut Air Bridge, Desert Shield, Desert Storm, Joint Guard, Joint Endeavor, Enduring Freedom, Iraqi Freedom and the Global War on Terror). The Aerospace Science Instructor (ASI) is Master Sergeant (MSgt) Mark Janik, USAF (Retired). MSgt Janik has 26+ years in the Air Force in a multitude of assignments, to include over 10 years of leadership and drill experience as a Military Training Instructor at Lackland Air Force Base. He too served through a wide array of military operations, to include Desert Shield and Desert Storm while working as a crew chief on the KC-10 aircraft.

The Texas 861st is managed and operated by Cadet Officers and Non-Commissioned Officers. It is through this cadet organization that cadets effectuate the management and hands-on leadership skills taught in the classroom.

This “Cadet Guide” contains policy, requirements, and rules of conduct for AFJROTC cadets at Westwood High School. Each cadet is required to study this guide and will be held responsible for its contents. The cadet guide should be used in addition to the Westwood High School’s “Student-Parent Handbook”. The intention of the two guides is to establish standards for the betterment of all students and promote self-discipline. **Failure to meet cadet standards may be grounds for removal from the Air Force Junior ROTC program.**

I wish you the utmost success, personal satisfaction and growth as members of the Westwood High School AFJROTC program. Congratulations on your decision to become a part of the TX-861st!

Laurelyn Arterbury, Principal
Westwood High School

WESTWOOD HIGH SCHOOL

2014-2015

(Revised 8/12/14)

12400 Mellow Meadow Drive / Austin, TX 78750
 Phone: (512) 464-4000 Fax: (512) 464-4020
 www.roundrockisd.org/westwood

2014		August			2014	
Su	M	T	W	Th	F	Sa
					1	2
3	4	5	6	7	8	9
10	11	12	13	14	15	16
17	18	19	20	21	22	23
24	25	26	27	28	29	30
31						

September						
Su	M	T	W	Th	F	Sa
	1	2	3	4*	5	6
7	8	9	10	11*	12	13
14	15	16	17	18*	19	20
21	22	23	24	25*	26	27
28	29	30				

October						
Su	M	T	W	Th	F	Sa
			1	2*	3	4
5	6	7	8	9*	10	11
12	13	14	15	16*	17	18
19	20	21	22	23*	24	25
26	27	28	29	30*	31	

November						
Su	M	T	W	Th	F	Sa
						1
2	3	4	5	6*	7	8
9	10	11	12	13*	14	15
16	17	18	19	20*	21	22
23	24	25	26	27	28	29
30						

December						
Su	M	T	W	Th	F	Sa
	1	2	3	4	5	6
7	8	9	10	11	12	13
14	15e	16e	17e	18e	19	20
21	22	23	24	25	26	27
28	29	30	31			

OPEN HOUSE
September 10

PROGRESS REPORTS
(approximate date)

Sep 19
Oct 31
Dec 12
Jan 30
March 13
May 1

REPORT CARDS
(approximate date)

Oct 10
Nov 14
Jan 9
Feb 20
Apr 17
June (mailed)

SIX-WEEKS PERIODS

1st Aug 26 - Oct 3
2nd Oct 6 - Nov 7
3rd Nov 10 - Dec 18
4th Jan 6 - Feb 13
5th Feb 17 - Apr 10
6th Apr 13 - June 4

PSAT - Oct. 15
SAT - Feb. 25

EOC Testing Windows:
December 1-4
Mar. 30 - English I
Mar. 31 - English II
May 4-7

AP Testing
May 4-15

Orange Days

New Teachers

Staff Dev.

Holidays

e=Semester Finals

* = Late Start Days
(Dept. Planning)

Feb 16 - Bad Weather Day #1
Apr 3 - Bad Weather Day #2

2015		January			2015	
Su	M	T	W	Th	F	Sa
				1	2	3
4	5	6	7	8	9	10
11	12	13	14	15*	16	17
18	19	20	21	22*	23	24
25	26	27	28	29*	30	31

February						
Su	M	T	W	Th	F	Sa
1	2	3	4	5*	6	7
8	9	10	11	12*	13	14
15	16	17	18	19*	20	21
22	23	24	25	26*	27	28

March						
Su	M	T	W	Th	F	Sa
1	2	3	4	5*	6	7
8	9	10	11	12*	13	14
15	16	17	18	19	20	21
22	23	24	25	26*	27	28
29	30	31				

April						
Su	M	T	W	Th	F	Sa
			1	2*	3	4
5	6	7	8	9*	10	11
12	13	14	15	16*	17	18
19	20	21	22	23*	24	25
26	27	28	29	30*		

May						
Su	M	T	W	Th	F	Sa
					1	2
3	4	5	6	7	8	9
10	11	12	13	14	15	16
17	18	19	20	21	22	23
24	25	26	27	28	29	30
31						

June						
Su	M	T	W	Th	F	Sa
	1e	2e	3e	4e	5	6
7	8	9	10	11	12	13

Homecoming: October 10, 2014
 Prom: April 11, 2015
 Graduation: June 5, 2015, 8:00 a.m.

Table of Contents

About This Guide.....	ii
References.....	iii
Program Overview.....	iii
Curriculum Components.....	iv
Extracurricular Activities.....	iv
Special Teams.....	v
Co-Curricular Activities.....	vi
Community Service Opportunities.....	viii
History of AFJROTC.....	ix
Chapter One: Mission, Goals and Expectations.....	1
Chapter Two: Basic Cadet Knowledge.....	2
Chapter Three: Core Values and the Honor Code	9
Chapter Four: Cadet Responsibilities and Behavior.....	10
Chapter Five: Conduct, Customs and Courtesies.....	13
Chapter Six: Songs, Pledges and Poems.....	16
Chapter Seven: Appearance of Cadet.....	19
Chapter Eight: Cadet Uniform Wear.....	21
Chapter Nine: Clothing and Equipment Account.....	33
Chapter Ten: Progression, Organization Charts and Job Descriptions.....	34
Chapter Eleven: Cadet Personnel Boards.....	36
Chapter Twelve: The Cadet Promotion System.....	38
Chapter Thirteen: Awards and Decorations.....	45
Chapter Fourteen: Classroom Procedures.....	50
Chapter Fifteen: Staff Meeting Procedures.....	53
Chapter Sixteen: Cadet Staff Office.....	54
Chapter Seventeen: Instructor Office and Logistics Area.....	55
Chapter Eighteen: Orders.....	56
Chapter Nineteen: Admission, Transfer, Completion, and Disenrollment.....	57
Chapter Twenty: Computer Usage.....	59
Chapter Twenty One: Hazing.....	60
Chapter Twenty Two: Evaluation and Grading System.....	61
Chapter Twenty Three: Merit/Demerit System.....	62
Chapter Twenty Four: Disciplinary Action.....	65
Chapter Twenty Five: Outstanding Flight Competition.....	66

Appendix

- A. Cadet Staff Job Descriptions
- B. TX-861st Unit Manning Document
- C. TX-861st Promotion Checklist
- D. Military Letter Format
- E. AFJROTC Awards and Decorations Chart
- F. AFJROTC Awards and Decorations Descriptions
- G. AFJROTC Badges
- H. AFJROTC Insignia
- I. USAF Grades and Insignia
- J. TX 861st Promotion Board Score Sheets
- K. Drill and Ceremonies Common Terms
- L. AFJROTC Inspection Standards
- M. Female Hair Standards
- N. Male Hair Standards
- O. How to Tie a Tie
- P. AFJROTC Merit and Demerit Form
- Q. Curriculum Plan
- R. TX 861st Organizational Chart
- S. Westwood Orange/White Calendar

About this Guide

This guide, affectionately referred to as the “**Blue Book**” contains the rules, regulations, policies and procedures for all aspects of AFJROTC Detachment TX-861. Thorough knowledge and conformity to its requirements will ensure success for each of you (henceforth known as “cadets.”) It is the responsibility of each cadet to become familiar with the materiel contained within. Certain items must be committed to memory. We proudly advertise that our JROTC program is “cadet run.” It starts with knowing this information. Every cadet from the corps commander to the newest recruit contributes to our success....or failure. For better or for worse, this program will be shaped by you. You are now an AFJROTC “owner.” In addition to complying with this guide, it is your responsibility to ensure that others comply with it as well. Our corps will be world class ***IF*** you dedicate yourself to making it so. Only through your personal efforts will the program become what *you want it to be.*

...What do *you* want it to be?

By necessity, this guide cannot cover every possible situation. In addition to this guide, additional information regarding JROTC operations may be found in the following references:

- ◇ Title 10, United States Code, Section 2031-2033, JROTC Program
- ◇ Public Law 104-208, Section 625
- ◇ DoDI 1205.13, JROTC PROGRAM
- ◇ AFJROTCI 36-2001, AIR FORCE JUNIOR ROTC OPERATIONS
- ◇ AFJROTC REFERENCE GUIDE
- ◇ AFJROTC ASSESSMENT GUIDE
- ◇ AFI 36-2903, DRESS AND PERSONAL APPEARANCE OF AIR FORCE PERSONNEL
- ◇ AFJROTC UNIFORM AND AWARDS GUIDE
- ◇ CURRICULUM IN ACTION GUIDE
- ◇ TX-861 Website, Instructor Page

The Cadet Inspector General (IG) is the Office of Primary Responsibility (OPR) for this guide. Any disputes regarding the correct interpretation will be researched and adjudicated by the IG. Recommendations for changes to the guide should be directed to the IG who will gather inputs and recommend changes to the SASI/ASI. The final decision for any changes rests with the Instructors, who ensure that any changes support applicable AFJROTC instructions and guidance. Prior to publishing a new version of the guide, the IG will thoroughly coordinate changes with the command staff and flight commanders.

Program Overview

The AFJROTC is not a “club” or “class”...it is a complete academic “lettering” program awarding Physical Education and Elective Credit with **NO MILITARY COMMITMENT!** The curriculum consists of an Aerospace Science (AS) component, a Leadership Education (LE) component, and a Health & Wellness (HW) component:

- **Aerospace Science (AS)** acquaints students with the elements of aerospace and the aerospace environment. It introduces them to the principles of aircraft flight and navigation, the history of aviation, development of air power, contemporary aviation, human requirements of flight, cultural and global awareness, geography, the space environment, space programs, space Technology, rocketry, propulsion, the aerospace industry, and survival.
- **Leadership Education (LE)** is the portion of the AFJROTC curriculum that develops leadership skills and acquaints students with the practical application of life skills. The leadership education curriculum emphasizes discipline, responsibility, leadership, followership, citizenship, customs and courtesies, cadet corps activities, study habits, time management, communication skills, career opportunities, life skills, financial literacy, management skills, and drill and ceremonies.

- **Health and Wellness Program (HW)** is an official and integral part of the Air Force Junior ROTC program. The objective of the Wellness Program is to motivate cadets to lead healthy, active lifestyles beyond program requirements and into their adult lives.

Being in JROTC means giving yourself a chance to learn what it takes to become successful not only in school, but in life. It means listening to your parents' and teachers' advice and testing that advice in an academic environment. After learning and testing the knowledge you've gained, you will be better prepared to serve your community and nation.

Our highly acclaimed curriculum is provided by HQ Air Force for a 4-year plan. The TEKS covered in the lesson plans cover: Science, Math, Social Studies, History, English, Speech and Writing. These Curricula are approved through SACS CASI and incorporate the revised Bloom's Taxonomy and Worldwide Instructional Design System model for 21st century outcome based teaching and learning.

Curriculum opportunities include:

- **Aerospace Science Academic Education**
 - Aviation History
 - The Science of Flight
 - Exploring Space
 - Cultural Studies
- **Character education**
- **Life skills and career education**
- **Leadership and Team Building Training**
 - Corps Job Assignments
 - Management of the Cadet Corps
 - Task Planning and Execution

We offer several avenues for involvement in AFJROTC functions outside of the normal academic settings. We encourage all cadets to take part in these activities to the maximum extent possible. JROTC activities fall into two categories: extracurricular and co-curricular.

Extracurricular Activities. Extracurricular activities either directly or indirectly support JROTC curriculum. However, due to the nature of these activities, UIL rules will be enforced for participation. Participation in special teams allows cadets to build camaraderie, demonstrate skills before the public, learn the importance of practice and discipline, and engage competitively in an interscholastic environment. Cadets will be required to sign a commitment to these activities and cadets are expected to attend all practices, meetings and competitions, performances, presentations, and/or demonstrations. A commander from each team will be selected from a pool of volunteers (see NOTE below). These activities meet after school, typically daily from 1630-1730. No "team activities" are scheduled for Fridays but may be needed (Color Guard for example) for game day presenting. Examples of extracurricular activities include, but are not limited to:

- **Kitty Hawk Air Honor Society (KHAS).** KHAS is the nationally recognized academic honor society of AFJROTC. Its purpose is to promote high academic standards and achievement in AFJROTC. In general, KHAS is open to the top 20% of the eligible population (10th-12th grade cadets), have a minimum 3.2/4.0 or 4.2/5.0 GPA. Other requirements are in the KHAS charter.
- **Recruiting and Awareness Presentation Team (RAPT).** Members of RAPT provide positive role models for elementary and middle school student by providing practical applications of the leadership education portion of the AFJROTC curriculum. Members also recruit new cadets. The team is responsible for selecting topics, conducting research, writing and presenting the material. Suggested topics include but are not limited to: The negative effects of drugs and alcohol, service, patriotism, etc. The SASI/ASI will coordinate with the principals of host schools. To join the team you must be a committed cadet with experience who has a good knowledge base of the TX-861st along with having good moral character, personal appearance, dependability, and discipline. Moreover you must meet the following requirements as well:
 - Must have completed AS-1 first semester
 - Must be on another team
 - Must have a corps job
 - Must be passing all classes
 - Must not have any disciplinary actions
- **Rocketry.** Model rocketry is the designing, building, and flying of small rockets that are made of paper, plastic, balsa wood, or any other lightweight material. Plastic models may be built in addition to building and flying gas or electric remote control aircraft...to include the development of a UAV (Unmanned Aerial Vehicle) reconnaissance aircraft/program. The club provides an exciting introduction for cadets to concepts of aerospace engineering and design and the basic concepts of flight and space. It can motivate cadets to attain a greater knowledge of aerospace studies and arouse interest in aerospace careers.
- **Color Guard:** This is a special marching unit which carries and ceremonially presents the U.S. and Texas flags at parades, school, and civilian events. Cadets who participate in at least five performances and attend 75 percent of color guard practices will be awarded the color guard ribbon at the Awards Banquet.
- **Drill:** (Armed and Unarmed) This is a precision marching group that performs in parades and at selected drill meets. Cadets who participate in at least two performances and attend 75 percent of drill team practices will be awarded the drill team ribbon at the Awards Banquet.
- **Saber Arc:** This is a precision marching group that performs in parades and at selected ceremonies. The saber team will be composed of members of Drill Team and will be commanded by the drill team commander when the need arises. Cadets who participate in at least two performances and attend 75 percent of drill team practices will be awarded the saber team ribbon at the Awards Banquet.
- **Physical Training:** The goals of the TX-861 physical fitness program are to develop an appreciation for lifelong physical fitness and to encourage physical fitness goals beyond the minimum. Criteria for the physical fitness ribbon are in the physical fitness officers training book in the cadet staff area above the computer.

- **Other Special Teams.** Our special teams may also include:
 - Rifle
 - Academic
 - Marksmanship
 - Cyber Patriot
 - Other opportunities available, based on cadet initiative.

Note: Each Team Commander will be required to compose a SOP (Standard Operating Procedure) when the semester begins. This SOP should contain all information regarding team expectations, everyday operational procedures, awards, and the TQS (Team Qualification Sheet). The Operations Squadron Commander will provide team commanders with a model on how to draft a SOP at the beginning of the year.

Co-curricular Activities. Co-curricular activities are events that directly support the academic curriculum of JROTC but do not fall under UIL rules. However, the SASI may set academic, participatory or other prerequisites for your participation. Examples of co-curricular activities include, but are not limited to:

- **Curriculum in Action (CIA) Trips.** A CIA trip is a voluntary (not graded) overnight excursion designed to expose cadets to military culture and/or history. We traditionally offer 1 CIA trip each semester. The Fall CIA trip is open to any cadet interested and the Spring CIA trip is only offered to those cadets in good standing and passing all their classes. Neither trip is set in stone, and we continually look for additional locations for these trips.
- **Military Ball.** The different JROTCs in RRISD put on a joint military ball each Spring highlighting military customs and courtesies. This ball is similar to a prom. Male cadets will wear their uniform. Female cadets may wear their uniform or a dress. Guests will wear appropriate civilian attire.
- **Awards Banquet.** Annually, late in the spring semester, a dinner and awards night is held to recognize outstanding cadets for their efforts during the school year. Local awards, AFJROTC awards, and national awards are presented at this time.
- **Field Days.** Field days may be either intramural or interscholastic and are intended to test the strength, coordination, endurance, teamwork and general physical condition of our cadets. They also build a critical amount of teamwork skills and esprit-de-corps within the 861st. Field days are an extension of our Health and Wellness program. We may also develop an RRISD “Interservice” field day competition between all the ROTC units in Round Rock with an overall “Commander’s Trophy” to be held by the winning unit for the entire year.
- **Commander’s Call.** Periodically the, Cadet Corps Commander will host a commander’s call to discuss offer his/her vision for the corps, encourage/rebuke the corps and/or discuss topics relevant to the commander and/or command staff. The intent is to educate and support leadership and followership, academic training and reinforce the chain of command and morale within the TX-861st.
- **Ceremonies.** Periodically, military ceremonies to present awards, announce promotions and change of command will be scheduled. These events reinforce the culture of honor within AFJROTC.

- **Professional Military Education (PME).** These schools exist to provide basic, intermediate and advanced military training necessary for the effective accomplishment of AFJROTC organizational functions. Currently, three opportunities for PME exist. The schools are:
 - **New Student Orientation.** Affectionately known as “Fish Camp,” new student orientation is planned and conducted by the flight commanders and AFJROTC command staff. Cadets new to AFJROTC will be exposed to the opportunities offered to, and requirements required from a TX-861st AFJROTC cadet. New student orientation occurs the week before school starts and cadets should not consider this to be optional. Cadets that participate could be advanced in rank for Cadet Airman upon graduation.
 - **Summer Leadership School (SLS).** This school is offered at the Westwood Campus and is designed for cadets completing their first year of AFJROTC. It is designed to consolidate their learning from their first year and prepare them to accept greater responsibility for the cadet corps. The program is offered to all interested cadets after their first year (or second year, if cadet was not available) for training. SLS is normally conducted within the first three weeks after the end of school. We also invite AFJROTC cadets from McNeil to participate in our school and are rewarded with cross-cultural discussions and collaboration within the two programs.
 - **Cadet Staff Leadership Lab (CSLL).** This school is offered on the Campus of Howard Payne University in Brownwood, Texas and is designed for cadets who have previously completed SLS and are expected to become senior leaders the following year. Promising cadets that have not attended SLS may be nominated to attend at the SASI/ASI discretion. Selection for this course is highly competitive and we typically can send no more than 10 cadets.

Community Service Opportunities

In an effort to produce well-informed and helpful citizens, we require cadets to get involved in our community. This is one of the most interesting and fun aspects of the AFJROTC experience and there are ample opportunities to participate. We start our community service in August helping the teachers, administration, and students prepare for the new year. Our participation is only limited by our imagination. Here are some of our other activities:

- Helping other student organizations with their events,
- Helping issue textbooks to all students,
- Helping at Freshman Orientation Night/Fish Bowl/Parent Night/Open House,
- Helped others schools with their events, such as school carnivals and presentations,
- Providing daily flag details at Westwood,
- Community Parades, Patriots Day, Veteran’s Day Ceremonies,
- Providing cadets and color guards for Football games, Basketball games, Military ceremonies,
- Provide support for MS-150 and MS-Walk, Supporting Project Graduation and more.

NOTE – Community Service hours, Fundraising and Co-curricular Trips: Each cadet is required to perform a minimum of 15 service hours as an AFJROTC activity to the school, community, or corps, and sell a minimum of \$100.00 in a corps fundraiser (greenery or other corps fundraiser) to be eligible to participate in the Spring CIA trip (see Individual Financial Account below). If no sales are made and the cadet desires to go on the trip, he/she is required to defray the cost of the trip or make a \$100 donation to the corps. Also, remember it is a privilege, not a right; to go on a field trip and inappropriate behavior will not be tolerated.

Individual Financial Account: A "paper" account is maintained for each cadet by the C/Finance Officer. Each cadet obtains "accounting" of funds as follows: \$0-\$100 = cadet get 15% into their paper account to spend toward corps activities such as trips, military ball, awards night. NO cash is transferred to the cadet! With \$101-\$500 in sales, the cadet gets 25% into their paper account and with over \$501 in sales, the cadet earns 30%. In these higher sales categories, it is easy for a cadet to achieve enough money to pay most of their own expenses for the year. Again, this paper account may only be used to offset the expense of trips, military ball, and awards banquet by the cadet. The remaining balance in the "paper" account for individual cadets will not be carried over to the next school year.

History of Air Force Junior Reserve Officer Training Corps

Air Force Junior Reserve Officer Training Corps (JROTC) can track its heritage to a program founded in 1911 in Cheyenne, Wyoming, by Army Lt Edgar R. Steevers. Lieutenant Steevers was assigned as an inspector-instructor of the organized military of Wyoming. During his assignment, he envisioned a noncompulsory cadet corps comprised of high school students. His program was aimed toward making better citizens.

The National Defense Act of 1916 authorized a junior course for non-college military schools, high schools and other non-preparatory schools. The Army implemented JROTC in 1916. Public Law 88-647, commonly known as the ROTC Vitalization Act of 1964, directed the secretaries of each military service to establish and maintain JROTC units for their respective services. The first Air Force JROTC programs were opened in 1966.

"(The) purpose of Junior Reserve Officers' Training Corps [is] to instill in students in United States secondary educational institutions the value of citizenship, service to the United States, personal responsibility, and a sense of accomplishment." (10 USC Sec 2031).

Air Force JROTC (AFJROTC) is a continuing success story. From a modest beginning of 20 units in 1966, AFJROTC has grown to 879 units throughout the world, with 102,000 cadets. The AFJROTC program positively influences our country by helping one student at a time. Comprised solely of active duty Air Force retirees, the AFJROTC instructor force is helping to form tomorrow's nation by educating proud and patriotic cadets—**tomorrow's leaders**.

CHAPTER 1

Mission and Goals

Mission and Objectives of AFJROTC:

"Develop citizens of character dedicated to serving their nation and community."

Goals:

The goals of AFJROTC are to educate, train and instill in high school cadets the values of:

- a. Citizenship
- b. Life Skills
- c. Personal Responsibility
- d. Sense of Accomplishment
- e. Self-Discipline
- f. Service to the school, community, and the AFJROTC corps
- g. Service to the United States

The AFJROTC cadet is expected to:

- a. Develop a high degree of personal honor, self-reliance and leadership
- b. Show interest in making the best decisions possible for life and career
- c. Develop a habit of orderliness and precision
- d. Promote the best in school spirit
- e. Create and maintain higher standards than other high school students
- f. Manifest in life the high principles our school offers
- g. Respect our teachers, appointed officers and classmates
- h. Obey lawful orders or instructions from our teachers, appointed AFJROTC officers, and non-commissioned officers
- i. Recognize and appreciate the sacrifices our parents/guardians have made to further our education and show them all due respect and gratitude
- j. Revere my country, the flag, and to take pride in wearing my AFJROTC uniform
- k. Develop patriotism and an understanding of their personal obligation to contribute toward national security
- l. Develop basic military skills
- m. Know and appreciate the traditions, customs and courtesies of the United States Air Force

CHAPTER 2

Basic Cadet Knowledge

While knowledge of *everything* in this guide is paramount, Chapters 2, 3 and 6 contain the basic knowledge that every cadet in the corps **MUST** know. There will be periodic tests of the knowledge contained within this chapter in class, at team practices, at drills, and during uniform inspections.

Phonetic Alphabet:

The phonetic alphabet provides a word designation to every letter in the English alphabet.

- A. Alpha
- B. Bravo
- C. Charlie
- D. Delta
- E. Echo
- F. Foxtrot
- G. Golf
- H. Hotel
- I. India
- J. Juliet
- K. Kilo
- L. Lima
- M. Mike
- N. November
- O. Oscar
- P. Papa
- Q. Quebec
- R. Romeo
- S. Sierra
- T. Tango
- U. Uniform
- V. Victor
- W. Whiskey
- X. X-Ray
- Y. Yankee
- Z. Zulu

Time:

All events within the corps are scheduled in 24hr (commonly known as military) time. It is essential that all cadets are able to understand and convert between both time formats.

2400 = 12 A.M.	0600 = 6 A.M.	1200 = 12 P.M.	1800 = 6 P.M.
0100 = 1 A.M.	0700 = 7 A.M.	1300 = 1 P.M.	1900 = 7 P.M.
0200 = 2 A.M.	0800 = 8 A.M.	1400 = 2 P.M.	2000 = 8 P.M.
0300 = 3 A.M.	0900 = 9 A.M.	1500 = 3 P.M.	2100 = 9 P.M.
0400 = 4 A.M.	1000 = 10 A.M.	1600 = 4 P.M.	2200 = 10 P.M.
0500 = 5 A.M.	1100 = 11 A.M.	1700 = 5 P.M.	2300 = 11 P.M.

Key Abbreviations and Acronyms:

AETC – Air Education and Training Command
AFB – Air Force Base
AFI – Air Force Instruction
AFJROTC – Air Force Junior Reserve Officers’ Training Corps – High school program
AS – Aerospace Science
ASI – Aerospace Science Instructor
AU – Air University
CC – Commander
CV – Vice-Commander
CSLL – Cadet Staff Leadership Laboratory
CIA – Curriculum in Action is the term used to identify school sponsored activities –Field Trips.
DoD – Department of Defense
HQ – Headquarters, located at Maxwell AFB, Alabama
KHAS – Kitty Hawk Air Society – AFJROTC Honor Society
LE – Leadership Education
NCOIC – Noncommissioned Officer in Charge
OIC – Officer in Charge
PA – Public Affairs
PT – Physical Training
RAPT – Recruiting Awareness Presentation Team
SASI – Senior Aerospace Science Instructor
SECAF – Secretary of the Air Force
SLS – Summer Leadership School
USAF - United States Air Force
WINGS – Web Intensive New Gain System

TX-861st Chain of Command:

The chain of command is the flow of information and orders from one point to another. The following is the chain of command starting at the highest authority on the national level and ending with the group commander and deputy group commander of the TX-861st corps.

Commander in Chief

Secretary of Defense

Secretary of State

Secretary of the Air Force

Chairman of the Joint Chiefs of Staff

Air Force Chief of Staff

Commander of Air Education Training Command

Commander of Air University

Commander of AFOATS

Commander Air Force Reserve Officer Training Corps

Chief Master Sergeant of the Air Force

Principle of Westwood High School

Senior Aerospace Science Instructor

Aerospace Science Instructor

Cadet Group Commander

Cadet Deputy Group Commander

When was the U.S. Air Force Founded?

The United States Air Force became a separate military service on September 18, 1947, with the implementation of the National Security Act of 1947. The Act created the National Military Establishment, later renamed the United States Department of Defense, which was composed of three branches, the Army, Navy and a newly created Air Force. Prior to 1947, the responsibility for military aviation was divided between the Army and the Navy.

When was the TX-861st Founded?

Westwood High School opened in 1981 and the AFJROTC Unit “stood up” in the school’s fifth year, 1986. Our unit was the first unit started in Texas in 1986, hence the designation... TX-861.

Whom do you salute?

All officers/warrant officers of the armed forces, ROTC, and allied nations.

What is the rank insignia of a Command CMSgt?

The rank insignia of a Command CMSgt is a chevron of eight stripes, three inverted, with a star in the center and a smaller star in the field of blue where a 1st sergeant would wear his/her diamond.

What is the rank insignia of the CMSgt of the USAF?

The rank insignia of the CMSgt of the USAF is a chevron of eight stripes, three inverted, with a star in the center surrounded by a wreath, and the great seal of the United States, flanked by two smaller stars in the field of blue.



Pay Grades and Rank:

You are expected to know the pay grades of the armed forces and the rank in the USAF that corresponds to each grade, as well as the rank insignia for each rank.

<u>Pay:</u>	<u>Rank:</u>	<u>Acronym:</u>	<u>Insignia:</u>
E-1	Airman Basic	AB	No rank insignia
E-2	Airman	Amn	Chevron of 1 stripe with a star in the center
E-3	Airman First Class	A1C	Chevron of 2 strips with a star in the center
E-4	Senior Airman	SrA	Chevron of 3 stripes with a star in the center
E-5	Staff Sergeant	SSgt	Chevron of 4 stripes with a star in the center
E-6	Technical Sergeant	TSgt	Chevron of 5 stripes with a star in the center
E-7	Master Sergeant	MSgt	Chevron of 6 stripes, 1 inverted with a star in the center
E-8	Senior Master Sergeant	SMSgt	Chevron of 7 stripes, 2 inverted with a star in the center
E-9	Chief Master Sergeant	CMSgt	Chevron of 8 stripes, 3 inverted with a star in the center
O-1	Second Lieutenant	2nd Lt	Gold bar
O-2	First Lieutenant	1 st Lt	Silver bar
O-3	Captain	Capt	Two connected silver bars
O-4	Major	Maj	Gold oak leaf
O-5	Lieutenant Colonel	Lt Col	Silver oak leaf
O-6	Colonel	Col	Silver eagle
O-7	Brigadier General	Brig Gen	One silver star
O-8	Major General	Maj Gen	Two silver stars in a line
O-9	Lieutenant General	Lt Gen	Three silver stars in a line
O-10	General	Gen	Four silver stars in a line

AFJROTC Cadet Creed

- **I AM AN AIR FORCE JUNIOR ROTC CADET. I AM CONNECTED AND FAITHFUL TO EVERY CORPS OF CADETS WHO SERVED THEIR COMMUNITY AND NATION WITH PATRIOTISM**
- **I EARN RESPECT WHEN I UPHOLD THE CORE VALUES OF INTEGRITY FIRST, SERVICE BEFORE SELF, AND EXCELLENCE IN ALL WE DO**
- **I WILL ALWAYS CONDUCT MYSELF TO BRING CREDIT TO MY FAMILY, SCHOOL, CORPS OF CADETS, COMMUNITY, AND TO MYSELF**
- **MY CHARACTER DEFINES ME**
- **I WILL NOT LIE, CHEAT, OR STEAL**
- **I AM ACCOUNTABLE FOR MY ACTIONS AND DEEDS**
- **I WILL HOLD OTHERS ACCOUNTABLE FOR THEIR ACTIONS AS WELL**
- **I WILL HONOR THOSE I SERVE WITH, THOSE WHO HAVE GONE BEFORE ME, AND THOSE WHO WILL COME AFTER ME**
- **I AM A PATRIOT, A LEADER, AND A WINGMAN DEVOTED TO THOSE I FOLLOW, SERVE, AND LEAD**
- **I AM AN AIR FORCE JUNIOR ROTC CADET**

CHAPTER 3

Core Values and The Honor Code

Cadet Core Values:

Our Core Values parallel the U.S. Air Force standards. Cadets will use these to set the standard by which the TX-861st cadet corps is operated. It is imperative that cadets internalize them and hold each other to these standards at all times.

INTEGRITY FIRST

An unfaltering devotion to honesty, truthfulness, doing one's duty, and doing what is right even when no one is watching.

SERVICE BEFORE SELF

The giving of one's self to provide service to the community, school, AFJROTC and others in need.

EXCELLENCE IN ALL WE DO

The policy of embracing the most exacting of standards, regardless of the assignment, as well as striving for excellence in every venture.

Beyond these, all cadet actions should embody **PRIDE**: A sense of one's dignity and value; Self-respect.

PERFORMANCE: To carry out; to meet the requirements; to fulfill

RESPECT: To feel or show honor or esteem for; hold in high regard

INTEGRITY: Being of sound moral principle; honorable, truthful, doing what is right

DISCIPLINE: Self-control; a state of order based on rules and authority

EXCELLENCE: Excelling; superiority; surpassing goodness; doing your best

The AFJROTC Cadet Honor Code: (Taken from the Air Force Academy Cadet Honor Code)

*"I will not lie, cheat, or steal, nor tolerate among us anyone who does.
Furthermore, I resolve to do my duty and live honorably (so help me God)."*

These words provide the foundation for a personal code of ethics that will last the remainder of a cadet's life. This Honor Code is specific and clear. Complying with this code is every cadet's obligation.

CHAPTER 4

Cadet Responsibilities and Behavior

Each cadet will agree to abide by the rules and regulations of the Aerospace Science Department and to accept responsibility for the proper care and maintenance of his or her uniform, textbooks, and any other AFJROTC equipment. Each cadet is also responsible for his or her own debts. Failure to promptly pay cadet obligations may result in demerits, and further disciplinary action.

All cadets in the corps must sign an agreement of commitment at the beginning of the school year to the effect that they are required to participate in ordered activities or any activity that they have volunteered for unless there is an immediate emergency or they give notice five (5) days prior to an event. Failure to comply with given orders will result in disciplinary action.

Cadets will not engage in the following inappropriate behaviors at any time, in any location, in or out of uniform, during any activity associated with AFJROTC. These behaviors include, but are not limited to:

1. Consuming alcohol, drug use or abuse, tobacco use, horseplay, public display of affection, fighting, disparaging remarks, insubordination, disrespect, verbal threats, and physical attacks. Such behavior could result in cadet removal from the cadet staff or AFJROTC Program.
2. Hazing. Hazing is strictly forbidden. It is defined as the practice of directing someone of lesser rank to perform a humiliating act which entails the surrender of dignity and self-respect or a hazardous act which exposes one to physical danger or bodily harm.
3. Cyber-Bullying. In an increasingly electronic world, cyber bullies rely on technology to spread their torment to others. Cyber bullying occurs when teenagers use the Internet, cell phones, or other devices to send or post texts or images that are intended to hurt or embarrass their victims. Put differently, cyber bullies may attempt to destroy or smear a victim's reputation with emails, blogs, forum posts, text messages, and other electronic media. Additionally, parents and students alike should be aware that some instances of cyber bullying can cross the line and become criminal conduct. Texas law defines criminal harassment as "sending repeated electronic communications in a manner reasonably likely to harass, annoy, alarm, abuse, torment, embarrass, or offend..."
4. Requiring your fellow subordinate cadets to perform push-ups or any other physical activity as punishment is also forbidden. These activities may only be performed as part of a unit's regular physical training/wellness program while under the supervision of an AFJROTC instructor.
5. Harassment, such as improper or abusive language, and coercion of lower class cadets for personal gain, is strictly forbidden. Misuse of cadet authority will not be condoned nor tolerated.
6. Vulgar conduct and language are not acceptable. For such conduct, all cadets risk undermining their effectiveness as leaders.
7. Public Display of Affection (PDA) is described as any physical contact between two people. PDA while in any uniform (including Travel shirt) is not allowed anytime, anywhere. PDA in civilian attire is not allowed in the JROTC building, our outside areas to include the drill pad, or while at a JROTC sponsored meeting or event. "Hello/Goodbye" hugs and kisses are allowed when extended to family members.

Cadet Officer/Non-Commissioned Officer (NCO) Responsibilities:

The Cadet Officer or NCO has special leadership responsibilities by virtue of their achievement in becoming a Cadet Officer or NCO. They are expected to set a positive example at all times in all actions. The following are minimum standards of leadership expected of every Cadet Officer and Cadet NCO:

1. You must serve with **INTEGRITY**. Your word is your bond. If you say you will do something, you will do it in a timely manner and to the best of your ability. If you discover you are unable to meet an obligation for a legitimate reason you must immediately inform your commanding officer. All cadets must possess an unfaltering devotion to honesty, truthfulness, justice, and duty.
2. You must **LEAD BY EXAMPLE**. You are a leader and your subordinates will expect you to meet and exceed the standards of the TX-861st.
3. You must **SHOW CARE AND CONCERN** for your subordinates. If you show respect for them, they are more likely to respect you in return.
4. Cadets on staff must **PARTICIPATE REGULARLY** in AFJROTC activities. As a cadet staff member, you must participate actively on at least one team. You are expected to achieve at least 3 service hours per month, accumulating a minimum of 15 hours each semester. If you are unwilling or unable to consistently meet these commitments, you will be removed from your position and reduced in rank.
5. You are expected to **COMPLETE ALL DUTIES** without fail. Responsibilities such as flag details, team performances, fundraisers, volunteer activities, or committee assignments must be carried out in a positive, professional manner. You must recognize that failure to complete these assigned duties causes embarrassment to the unit, gives underclassman a loss of confidence in their superiors, and gives the impression that their leadership is not trustworthy.

NOTE: If you are unable to attend corps activities due to events beyond your control, you must inform your chain of command about your situation at least five days prior to the event. In the case of a last minute emergency, a phone call or email from a parent to the SASI or ASI is mandatory.

6. You are expected to **STAY INFORMED** of your responsibilities by regularly checking orders, listening to the flight briefing, and reading the boards in the classroom. School E-mail is the only "official" E-mail and must be checked regularly.
7. All staff members are expected to **PASS ALL CLASSES** at the end of each six weeks. If the Cadet Corps is to succeed in accomplishing its mission, it must have a cadet staff that is able to balance both academic and AFJROTC activities.

8. Cadet Officers/NCO's not passing at the end of the six weeks (report card) will be reprimanded in the following manner:
 - a. First reprimand
 - i. Letter of Counseling
 - ii. Removal of Staff Rope(s)
 - iii. Removal of Staff Room Privileges
 - iv. Not allowed to participate in UIL events
 - v. Mandatory Tutoring
 - b. Second reprimand:
 - i. Same as above
 - c. Third Reprimand:
 - i. Letter of Reprimand
 - ii. The cadet will be removed from his/her Staff Position and demoted to his/her permanent rank

CHAPTER 5

Conduct, Customs and Courtesies

1. GENERAL:

Cadets are expected to observe correct military conduct, customs and courtesies at all times. This will reflect credit upon themselves, their parents, the TX-861st, Westwood H.S., and the U.S. Air Force. Extend courtesies to everyone: officer enlisted, or civilian. You are never wrong to be polite.

Respect for Authority: Responsible and successful cadets develop respect for authority. Cadets will respect the authority given to other cadets. Cadets will extend the proper courtesy to every cadet, regardless of experience, age or school year.

- Cadets must first learn how to follow before they can learn to lead-A key aspect of followership is recognizing and respecting the legitimate authority of cadets placed in leadership positions over you. Failure to submit to legitimate authority disqualifies you from future leadership roles in AFJROTC
- Cadets will take responsibility for their own actions and the actions of those placed under their authority.
- You will only earn the respect of others by your example, never through attaining high rank or position.
- Cadets will not abuse their rank or authority. There is no room for egotists in senior leadership. Having a high rank or position should humble you, not make you proud. Pride should come from contributing to the successes of those who lead you and those placed under your care.
- A strong leader rarely has to pull rank when directing others. If you earn the respect of those under you, they will trust your judgment and follow you willingly. You must not issue orders arbitrarily. There must be a mission related need behind any order. Leaders must set a proper example at all times and for maintaining good order and discipline.
- Obey the rules you are enforcing. Don't be a hypocrite.
- Commanders are authorized to give lawful (legitimate) orders to cadets under their supervision. Commanders have no legitimate authority to order a cadet to break any rule, to issue orders to cadets not placed under their authority, to direct a cadet in their authority act or refrain from acting in any area not in their area of responsibility. No cadet has the authority to excuse another cadet from class or modify an existing order without the approval from the issuing commander or SASI/ASI.

Conduct:

- **Attitude:** Cadets will give their best effort while participating in corps activities. In life, you will meet with both triumph and disaster. You must learn to react to each with essential indifference. You cannot control either of them; you can only control your reactions to them. Perseverance in reaching for the ultimate prize will keep you focused on the task at hand.
- **Responsibility:** Cadets will keep their word. If a cadet says they will attend or participate in any event, they are expected to attend or participate. Others are counting on you and you must not let them down. There are very few good reasons for breaking your word. Forgetting is never one of them.
- **Academic Standards:** All JROTC cadets fall under the UIL “No Pass, No Play” policy of eligibility concerning participation in any JROTC related extra-curricular activities. For co-curricular activities, the SASI will decide if UIL rules will be in effect. Cadets assigned to the command staff are to flight commander position not meeting UIL academic standards at the end of a grading cycle will be placed on probation. Another cadet will be designated to perform their duties until the progress report, If the cadet has not brought the grade up to passing as of the next progress report, the SASI may permanently remove them from their position and a replacement will be selected, if required.

2. MILITARY COURTESY:

The practice of saying YES SIR/MA’AM or NO SIR/MA’AM to instructors and to cadets who outrank you is always observed in the program. This is a long established military courtesy and will be followed in the cadet corps. Another military tradition that is observed in the corps is calling rooms and areas to attention for superior officers. When any Principal, SASI or ASI, or a higher ranking cadet officer walks into the room or approaches an area where cadets are standing, it will be called to attention. The only exception is when entering the classroom.

3. SALUTING:

- a. The salute is a courteous exchange of military greetings for the world over. Military members consider the salute as a respectful greeting between members and it is one of the oldest traditions binding military professionals together.
- b. Saluting at Westwood High School is required everywhere outdoors on campus when in uniform. If a formal salute cannot be rendered, then a verbal greeting will suffice. A verbal greeting is required if recognized while out of uniform.
- c. The salute is accomplished indoors only when cadets are “reporting” to cadet officers or to the SASI. The proper sequence of reporting includes knocking once on the door and

rendering the salute and statement: "Sir/Ma'am, Cadet (rank and name) Reports as Ordered." The cadet holds the salute until it is returned or otherwise acknowledged by the officer. When the purpose of the meeting is completed, the cadet again salutes, the officer will return the salute and the cadet will take the most direct exit and leave. (Note: hands will not have pencils, pens, or other objects in them when saluting.)

- d. A salute is never given or returned while running. The cadet will come to quick time (a walk) and render the salute.
- e. Cadets in uniform outside at Westwood High School will render the hand salute during flag raising ceremonies. When indoors and in uniform, cadets will come to the position of attention.
- f. If a cadet in civilian clothes observes the American Flag being raised or lowered from any flagstaff, he/she will assume the position of attention and place the right hand over the heart. If a cadet is wearing civilian headgear, he will remove the headgear and hold it over his left shoulder so that the right hand is over the heart.

4. ON DUTY/OFF DUTY:

What this means is that on school days when a cadet is in the ROTC area, he/she will address superior officers by sir/ma'am. This is considered "On Duty". On Duty time also applies to all service projects and any AFJROTC affiliated event. Any other time or place is considered "Off Duty", meaning that there can be some informality. For example, when a staff officer is at lunch in the staff room, this time is considered "Off Duty."

CHAPTER 6

Songs, Pledges, and Poems

The following songs, pledges, and poem are provided to allow you to participate and get in the proper spirit at various functions.

THE STAR SPANGLED BANNER

O SAY, CAN YOU SEE, BY THE DAWN'S EARLY LIGHT,
WHAT SO PROUDLY WE HAILED, AT THE TWILIGHT'S LAST GLEAMING,
WHOSE BROAD STRIPES AND BRIGHT STARS,
THRO' THE PERILOUS FIGHT, O'ER THE RAMPARTS WE WATCHED,
WERE SO GALLANTLY STREAMING,
AND THE ROCKET'S RED GLARE, THE BOMBS BURSTING IN AIR,
GAVE PROOF THRO' THE NIGHT,
THAT OUR FLAG WAS STILL THERE.
O SAY, DOES THAT STAR-SPANGLED BANNER YET WAVE,
O'ER THE LAND OF THE FREE, AND THE HOME OF THE BRAVE?

THE PLEDGE OF ALLEGIANCE

I PLEDGE ALLEGIANCE TO THE
FLAG OF THE UNITED STATES OF
AMERICA AND TO THE REPUBLIC
FOR WHICH IT STANDS, ONE NATION,
UNDER GOD, INDIVISIBLE,
WITH LIBERTY AND JUSTICE FOR ALL.

TO THE FLAG OF TEXAS

HONOR THE TEXAS FLAG.
I PLEDGE ALLEGIANCE TO THEE,
TEXAS, ONE STATE UNDER GOD,
ONE AND INDIVISIBLE.

THE AIR FORCE SONG

OFF WE GO, INTO THE WILD BLUE YONDER,
CLIMBING HIGH, INTO THE SUN,
HERE THEY COME, ZOOMING TO MEET OUR THUNDER,
AT 'EM BOYS, GIVE-ER THE GUN!
DOWN WE DIVE, SPOUTING OUR FLAME FROM UNDER,
OFF WITH ONE, HELL-UV-A-ROAR,
WE LIVE IN FAME, OR GO DOWN IN FLAME,
HEY! NOTHING WILL STOP THE U.S. AIR FORCE



Minds of men fashioned a crate of thunder,
Sent it high into the blue;
Hands of men blasted the world asunder;
How they lived God only knew! (God only knew then!)
Souls of men dreaming of skies to conquer
Gave us wings, ever to soar!
With scouts before and bombers galore. Hey!
Nothing can stop the U.S. Air Force!

Bridge: "A Toast to the Host"

Here's a toast to the host
Of those who love the vastness of the sky,
To a friend we send a message of his brother men who fly.
We drink to those who gave their all of old,
Then down they soared to score the rainbow's pot of gold.
A toast to the host of men we boast, the U.S. Air Force!

Zoom!

Off we go into the wild sky yonder,
Keep the wings level and true;
If you'd live to be a grey-haired wonder
Keep the nose out of the blue! (Out of the blue, boy!)
Flying men, guarding the nation's border,
We'll be there, followed by more!
In echelon we carry on. Hey!
Nothing can stop the U.S. Air Force!

WESTWOOD HIGH SCHOOL ALMA MATER

On the edge of the west horizon
and reared against the sky,
is the home of the Westwood Warriors,
protected by our pride.

Onward, upward, ever forward
to the end we'll ever fight.
With our hearts, hands, and minds,
pledge to Westwood High, our light.

For the home of the Westwood Warriors,
will ever shine so bright.

Hail to Alma Mater;
Hail to Orange and White.



USE THE FOLLOWING SPACE FOR SPECIFIC FLIGHT OR ASI/SASI MEMORIZATION/NOTES:

CHAPTER 7

Appearance of Cadet

1. While enrolled in the AFJROTC program, cadets will comply with the personal appearance and grooming standards prescribed by the Air Force (AFI 36-2903, *Dress and Personal Appearance of Air Force Personnel*) and the *AFJROTC Reference Guide*. The Reference Guide outlines the different insignias which may be worn on your uniform and where these insignias should be placed on the AFJROTC uniform. If in doubt about proper grooming standards or placement of insignias on your uniform, consult your cadet group staff or AFJROTC instructors for guidance. Because you wear the official United States Air Force uniform with cadet rank, any objectionable behavior in public can create unfavorable public reaction toward the AFJROTC program and the Air Force. On the other hand, proper conduct, actions and attitude will create and sustain a favorable public reaction which will enhance the image of the TX-861 Cadet Corps and Westwood High School. As an Air Force Junior ROTC cadet, you must constantly strive to present a neat, clean, and well-groomed appearance. This is a graded area each week under leadership. Additionally, Cadets **are not** permitted to wear headphones/ear buds anywhere in the AFJROTC building UNLESS they are on Senior Staff and sitting/working in the Cadet Office. School Cell Phone policy will also be strictly enforced during the school day. **ALL RRISD and Westwood HS Dress Codes/Policies will be adhered to whether in or out of uniform.** For complete guidance, refer to the source documents above.
 - a. **MALE CADETS:** The face will be clean shaven but mustaches are permitted. If worn, mustaches will be neatly trimmed, must not extend downward beyond the lip and may not extend sideways beyond a vertical line drawn upward from the corner of the mouth. Beards and goatees are not permitted. **(Hair will be neat, clean, trimmed, and present a groomed appearance.)** Hair must have a tapered appearance on the sides and back, both with and without headgear. A tapered appearance is one that, when viewed at any angle, outlines the individual's hair so that it conforms to the shape of the head, curving inward to the termination point. The bulk of the thickness must not exceed $\frac{1}{4}$ inch at the termination point. A block cut is permitted as long as it is tapered in the same manner as the haircut. The sideburns must be even, (not flared) ending in a clean-shaven horizontal line. Sideburns must not extend below the lowest part of the exterior ear opening. The hair must be of natural color. **The uniform will not be issued to or worn by any cadet who fails to meet these standards.**
 - b. **FEMALE CADETS:** The hair must be styled to permit proper wear of the hat. It will not exceed three inches in bulk. It should always be clean, neatly arranged and styled to present a professional image. The hairstyle must not extend in length on any side below an invisible line drawn parallel to the ground at the bottom edge of the shirt collar at the back of the neck **(not worn longer than collar length)**. Hair ornaments such as ribbons will not be worn. Pins, combs, or barrettes similar in color to individual hair color may be worn.

2. Unacceptable Clothing and Accessories

General Information:

- No clothing featuring pictures, emblems, writings, or slogans that are lewd, offensive risqué, vulgar, obscene, provocative, or that convey hate messages or racially, religiously, or ethnically demeaning message may be worn (including jewelry or accessories).
- No apparel or accessories shall depict tobacco products, alcoholic beverages, drugs or any other dangerous, prohibited, or controlled substance
- No attire or grooming that identifies, condones, depicts, or promotes a student as part of an unauthorized group, such as a gang.
- No clothing or accessories that promote violence, weapons, bombs, illegal acts, or anything that could be construed as provocative or offensive or otherwise distract from the learning environment, as determined by the administrators.
- No bedroom attire (pajamas, slippers, etc.)
- No clothing that is too tight such as spandex/lycra unless worn with a dress, skirt, or tunic (using the standards that are applied to shorts, skirts, and skorts)
- No holes in apparel that expose any areas that are not allowed by this dress code

Pants, Jeans:

- Shorts, skirts, and skorts must be at finger-tip or mid-thigh length as measured with relaxed shoulders
- Pants, jeans, shorts, skirts, and skorts must be worn at the hip and cover undergarments

Shirts, Blouses, Sweatshirts, Sweaters, Vests, Jackets, Coats:

- No strapless tops, spaghetti-strap tops, backless, halters, large armholes, or off-the-shoulder tops
- No low necklines (which reveal cleavage)
- No see-through or mesh shirts, when shirt worn underneath does not meet this dress code
- Tops must meet the beltline, and must not reveal undergarments or skin
- No full-length jackets and coats such as those commonly referred to as “trench coats” or “dusters”

Eyewear and Accessories:

- Sunglasses shall not be worn in the building
- No metal-studded collars, choker chains, armbands, wristbands, chains, or other metal-studded accessories are permitted
- Piercings/accessories that pose a safety concern or are distracting (i.e. chain from nose piercing to ear) are prohibited
- No wheeled footwear

Headgear:

- Hats, caps, sweatbands, scarves, bandanas, doo-rags, hoods, and other headgear shall not be worn inside campus buildings without administrative approval

CHAPTER 8

Cadet Uniform Wear

This uniform, with the exception of the insignia, is the same as that worn by the USAF personnel. Once issued, failure to wear the uniform and wear the uniform correctly will result in removal from AFJROTC.

Uniform Requirements for Male and Female Cadets

- a. The flight cap is worn with the front crease toward the lower center of the forehead. When worn in this manner, the top crest of the cap will be fully extended without a protruding tip in the back. When **NOT** worn, tuck the cap flush with the top of the belt between the first and second belt loop on left side of pants with insignia facing outward. Caps will **NOT** be folded over or under the shoulder epaulets on the uniform.
- b. The belt is threaded through the loops to your **LEFT** (males) or **RIGHT** (females). When buckled the silver tip end of the belt extends beyond the buckle. No blue belt fabric shows between the tip and belt buckle. Belts **MAY BE CUT** to achieve the proscribed length.
- c. The shoes will be laced up to the top, with laces tucked in, and shined to a high gloss (including the heels and sides of the soles) at all times.
- d. The socks must be **BLACK**. Any other color socks are not authorized.
- e. The short sleeve blue shirt can be worn with the collar open. The shirttail is pulled down into the trousers tightly and tucked at the sides to make it nearly form fitting (military tuck). The only creases on the shirt are down the sleeves. Bulky items placed into the pockets of the shirt are not authorized. Shirt garters may be used for a clean, professional look.
- f. **THE BLUE TROUSERS MUST BE DRY-CLEANED.** The bottom of the trouser legs will touch the shoes in such a manner to cause a slight break in the crease. This alternation is provided by the Air Force. Articles carried in the pockets will not be visible.
- g. **THE BLUE SERVICE COAT AND LIGHTWEIGHT BLUE JACKET MUST BE DRY-CLEANED.** There are two pockets inside the coat for carrying small flat items (Male only). Outer garments such as the lightweight blue jacket will be removed when indoors. The service coat may be removed in the classroom. When it is removed, it will be carefully draped over the back of the chair. The coat will be properly worn and buttoned when leaving the classroom. The necktie or tie tab **WILL NOT BE REMOVED OR LOOSENED.**
- h. Blue shirts should be laundered after wearing. Light colored shirts **CAN BE WASHED** at home. After laundering, a **MEDIUM STARCH** will keep the shirt neat.

- i. **(MALE CADETS ONLY)** During formal occasions such as the Military Ball and Awards Banquet you may substitute the class “A” light blue shirt with a white button up shirt. The white shirt will have a plain white collar and be worn with the issued tie. This uniform is known as **informal class “A”**.

General Rules for Uniform Wear:

- a. **UNLESS INSTRUCTED OTHERWISE**, the uniform will be worn on Wednesday or Thursday depending on which day you have class. On these days, the uniform will be worn all day from 0905 to 1610 with the exception of cadets with an off block. If you are required to remove the uniform for another class, you must first receive permission from Maj Sandlin or MSgt Janik.
- b. Only authorized uniform items will be worn during uniform day. Do **NOT** mix uniform items with civilian clothing.
- c. All pockets will be kept buttoned. Hands will be kept out of the uniform pockets unless retrieving or placing an item there.
- d. Your “gig line” is the line formed by the edge of the shirt, the edge of the belt buckle, and the fly of the trousers. The “gig line” will always be kept straight.
- e. There will be no loose strings or frayed seams on the uniform, any loose strings or frayed seams found will be trimmed immediately.
- f. The light blue shirt will be kept tucked in at all times.
- g. Replace missing buttons promptly. See the Logistics Officer or NCOs for buttons.
- h. Make it a habit of carrying book bags and other objects in the left hand so that the right hand is free for saluting.
- i. Wrist watches, MIA identification bracelets, only three rings altogether total on both hands, and one pair of earrings (**on the ear lobe only-one per ear**) (pearl-like, gold, or silver spherical balls or studs) may be worn. **Only females are authorized to wear earrings.** One necklace may be worn, but it must be out of sight.
- j. The “T-shirt” (mandatory for all males) is to be worn under the male or female shirt; and will be plain (**no print or artwork**), white, “V” neck, and clean.
- k. The Logistics Officer will arrange for classes to sign up for any optional uniform items (corfam shoes, shirt garters, etc.). A cadet will need to pay for any optional uniform items that he/she will want for the year.
- l. Wear only black issue shoes and black socks with the uniform.

- m. Hitchhiking, performing manual labor, engaging in sport activities, protesting while wearing the uniform is not permitted.
- n. At the end of the school year, uniforms will be turned in as scheduled after they have been professionally cleaned. **Lost items must be paid for promptly. Remember, the uniform is United States government property and must be turned in.**
- o. The corps expects the wear and care of the uniform to be the cadet's responsibility, not the parents'. Cadets and parents must work together to ensure the uniform is ready to wear on uniform day
- p. Cosmetics (female) must be conservative. Red or pink lipstick and conservative eyeliner is authorized. Nail polish may be worn as long as it is the same conservative color on all nails. Designs, decorations, and/or decals are not allowed.
- q. Hair Styles (female) must present a feminine appearance. Must not exceed three inches in bulk or prevent the proper wear of headgear. Must not include hair ornamentation, such as ribbons or jeweled pins. Plain pins, combs, and barrettes similar in color to the cadet's hair color may be worn to keep hair in place. Hair must not pass/exceed the bottom edge of the collar in the back.
- r. Hosiery must be worn with the skirt and are optional with slacks. Hosiery will be plain commercial, sheer, nylon in neutral, dark brown, black or off-black, or dark blue shades that complement the uniform and the Airman's skin tone. Patterned hosiery is not authorized to be worn with any uniform..

BDU-SPECIFIC RULES:

- a. The blue name tag will be worn grounded and centered on the right pocket.
- b. Officer and enlisted grade insignia worn on both left and right collars, centered on collar and parallel with bottom of collar.
- c. The corps hat will be worn with the BDU uniform.
- d. A plain black T- Shirt or Corps black T-Shirt will be worn under the BDU shirt. Other black "Air Force" organizational or related T-Shirts may be authorized with SASI/ASI approval.
- e. The BDU shirt can be worn with sleeves up or down. When sleeves are up, the material will not touch or come within 1 inch of forearms when bent at 90- degree angle. The "cuff" will not exceed 3" in width.
- f. Trousers will be worn with the blue belt; trouser legs will be "bloused" over the boot.
- g. Black combat boots will be worn with the BDU uniform.

CLASS "H" SPECIFIC RULES:

- a. Class "H" is worn with the Corps shirt tucked into the pants.
- b. The Corps hat will be worn outside when in class "H".
- c. Belt and closed toed shoes will be worn with the class "H".
- d. All cadets must comply with grooming standards when wearing the class "H" uniform.

Distinctive uniform items may be worn by certain teams as authorized by HQ AFJROTC.

Uniform Items

1. Ribbons: Men- ribbons are worn with the bottom row of ribbons grounded at the top of the left pocket and centered on the pocket. Females- the bottom row of ribbons must be even with the bottom of the nametag 1 ½ inches above or below the first exposed button. Medals may be worn simultaneously with the ribbons when authorized locally for formal, semiformal, and special occasions. The order of precedence will be the same as for ribbons. (See Appendix E and F for ribbons, medals and their prerequisites for wear).
2. Ribbons of Other Services: AFJROTC cadets are authorized to wear ribbons earned while enrolled in Army, Navy, or Marine JROTC. Only five CAP ribbons (Gen. Spaatz Award, Amelia Earhart Award, Gen. Mitchell Award, Gen. Curry Achievement Award, and Gen. Eaker Award) are authorized to be worn on the AFJROTC uniform. Badges or insignia from non-AFJROTC groups are not authorized on the AFJROTC uniform.
3. Order of Precedence: The medal or ribbon with the highest precedence is worn nearest the lapel on the top and ribbons or medals with lower precedence are worn lower and furthest from the lapel.
4. Oak Leaf Clusters:
 - a. Bronze oak leaf clusters are worn on the ribbon to designate the second or subsequent award.
 - b. Silver oak leaf clusters are worn on the ribbon in lieu of five oak leaf clusters.
5. Badges: Once a badge is earned and awarded, it will be worn as shown in the guide (Appendix G)
6. Nametags: The standard Air Force blue nametag will be worn on all light blue shirts/blouses. Males wear the nametag grounded to the wearer's right pocket, centered on the pocket, and parallel to the ground. Females wear the nametag 1½ inches above or below the first button parallel to the ground on the wearer's right side. If issued, metal nametags will be worn on service coat.
7. Ranks: Ranks earned through the promotion system must be worn IAW with this guide.
8. AFJROTC Shoulder Patch: Wear of the official shoulder patch is mandatory on all outer garments except the raincoat, overcoat, and all weather coats. Cadets enrolled in Civil Air Patrol (CAP) and AFJROTC who use the same uniform for both activities may wear the CAP wing patch on the right shoulder and the AFJROTC patch on the left shoulder with the AFJROTC patch taking precedence.

9. TX-861 Unit Patch: Wear the AFJROTC patch on the left and the TX-861 unit patch on the right sleeve one inch below the outer shoulder seam, centered.
10. Shoulder Cords: The following cadets may wear shoulder cords
- | | |
|------------------------------------|--------------------------|
| a. White with two loops and braids | Inspector General |
| b. Silver | Group Commander & Deputy |
| c. Blue with two loops | Squadron Commanders |
| d. White | Staff Member |
| e. Red, White, and Blue | Cadet of the Quarter |
| f. Orange | Cadet of the Month |
| g. Orange & White | Outstanding Flight |
| h. Orange & Black | Drill Team Member |
| i. Blue & Black | Color Guard Team Member |
| j. Blue | Rocketry Team Member |
| k. Black | Guidon |
11. Service Caps (optional): All cadets are permitted to wear service caps. Caps and insignia must be purchased at cadet's own expense.

CADET MALE HEADGEAR

SERVICE CAP

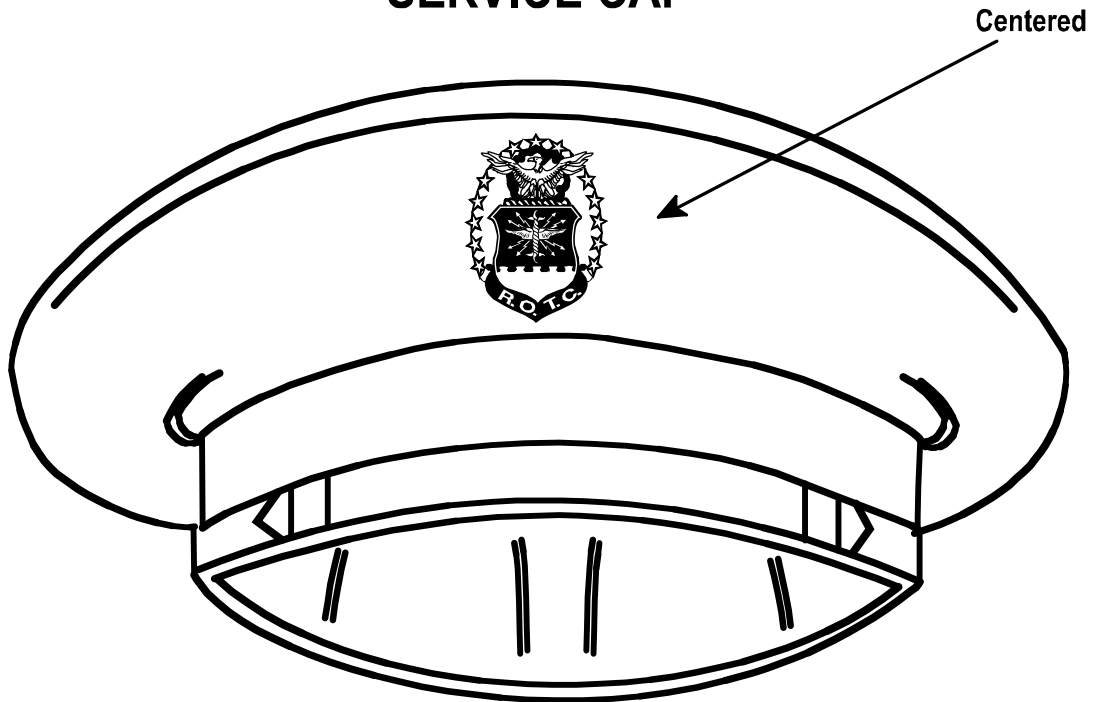

FLIGHT CAP

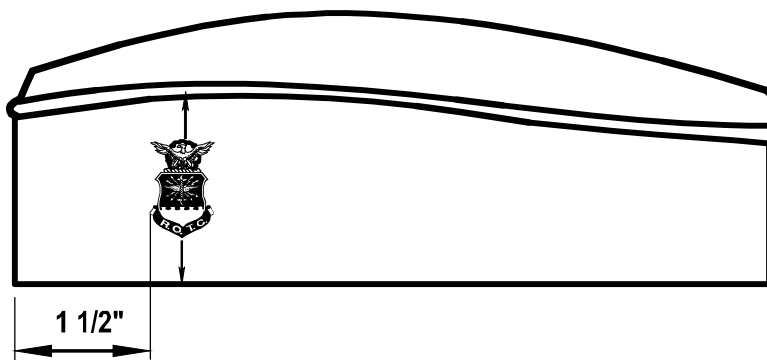

**centered top to bottom and
1 1/2 inches from front of cap**

Note: Only Cadet Officers wear insignia. Flight caps are worn two fingers from the eyebrows, three fingers from the top of the right ear, and four fingers from the top of the nose. Males will not have hair protruding in the front of any headgear.

CADET FEMALE HEADGEAR

SERVICE CAP

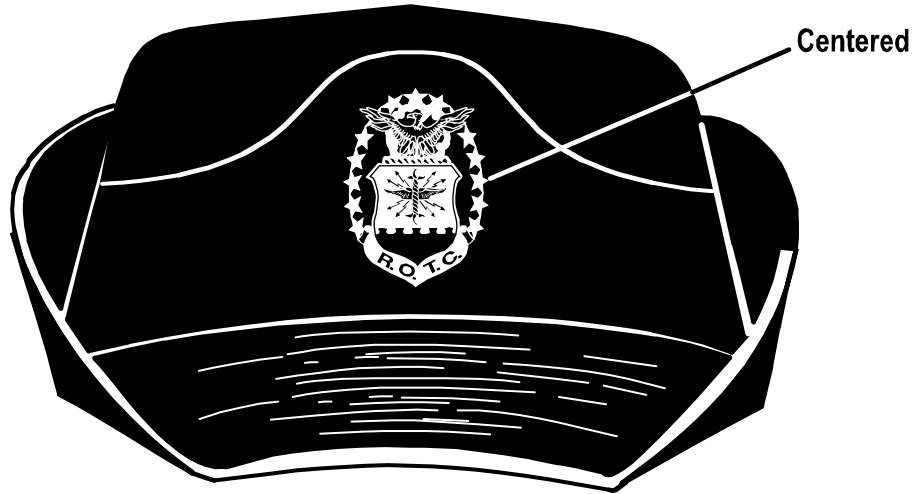

FLIGHT CAP

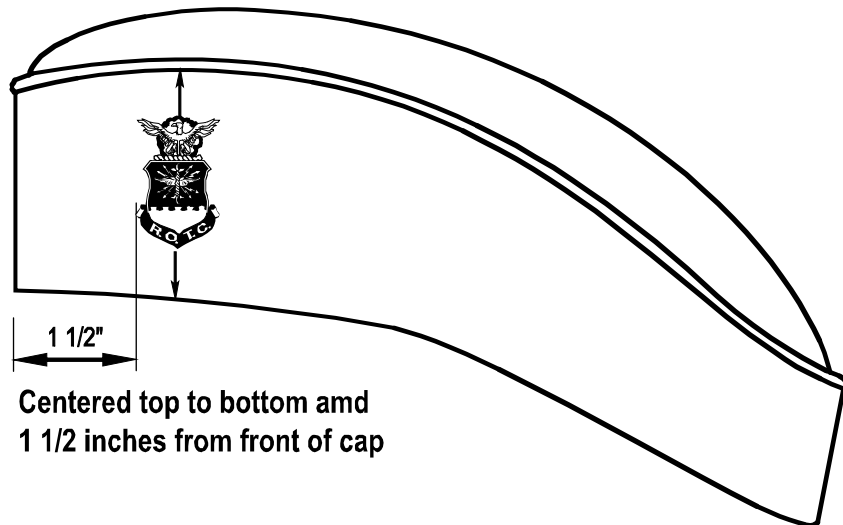

Note: Only Cadet Officers wear insignia. Flight caps are worn two fingers from the eyebrows, three fingers from the top of the right ear, and four fingers from the top of the nose. Only females may have hair protruding in the front of headgear and must not touch the eyebrows.

CADET MALE 1620 SERVICE DRESS

Note:

Officers: Hard ranks are on the coat and soft ranks are on the shirt.

Enlisted: Hard rank insignia must be on both shirt and coat.

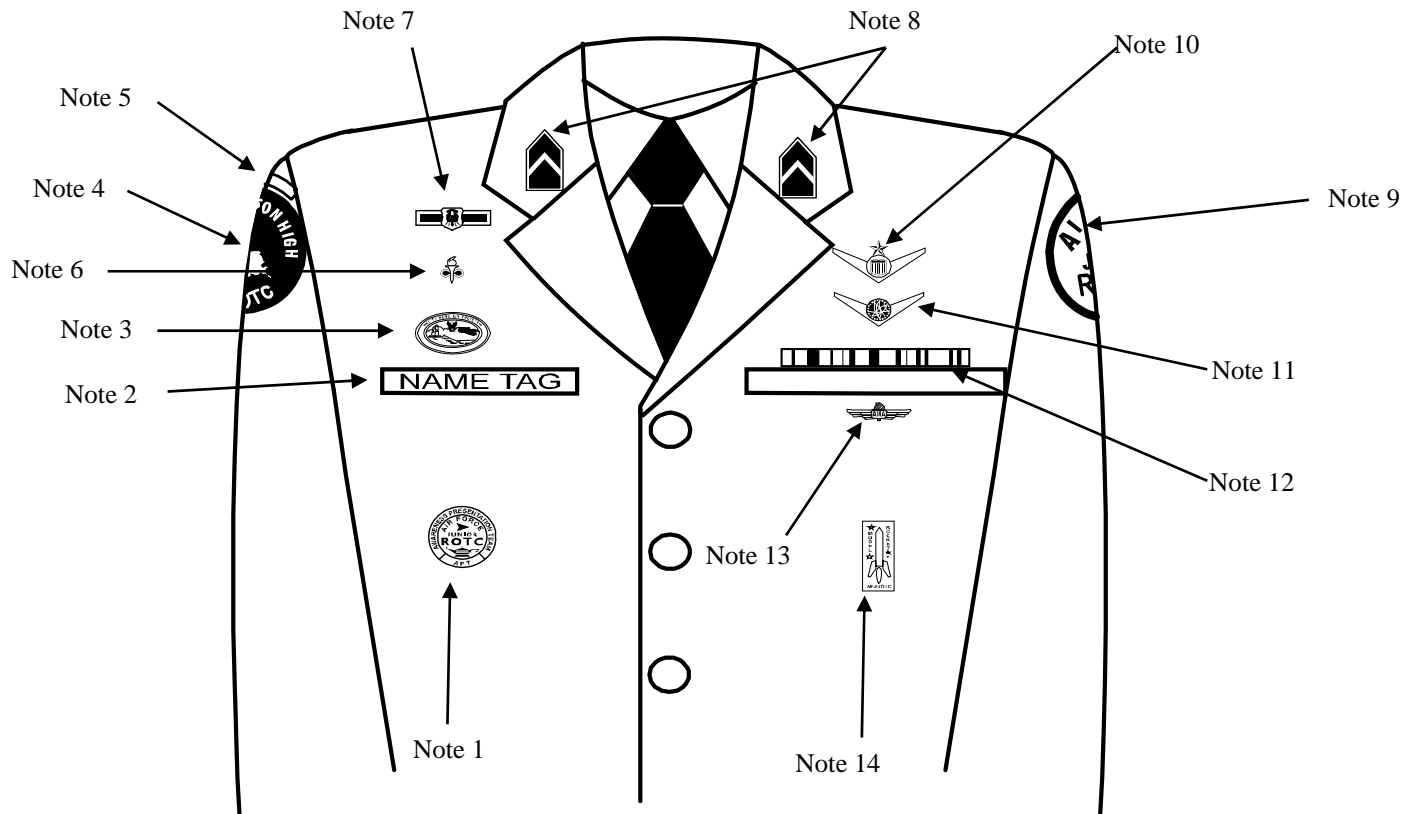

1. Awareness Presentation Team (APT) badge: Center on welt pocket 3 inches below the top.
2. Name tag: Center between arm seam and lapel with bottom edge parallel to top of welt pocket
3. Kitty Hawk Badge: see note 15.
4. Unit patch: Placed $\frac{1}{2}$ to 1 inch below shoulder seam and centered.
5. Shoulder tabs: Center between unit patch and shoulder seam. If no patch, then 1 inch below shoulder seam.
6. Aerospace Education Foundation (AEF) Badge: see note 15.
7. Distinguished Cadet Badge: see note 15.
8. Grade insignia (officer or enlisted) worn on both lapels. Airman Basic wears lapel insignia on both lapels. Place insignia halfway up the seam, resting on but not over it. Bottom of insignia is horizontal with the ground.
9. AFJROTC Patch: Placed $\frac{1}{2}$ to 1 inch below shoulder seam, and centered.
10. Flight Solo or Flight Certificate Badge: see note 15.
11. Ground School Badge: see note 15.
12. Ribbons: Center, on but not over edge of pocket. Wear 3 or 4 in a row. Wear all or some.
13. Academy of Model Aeronautic Wings: worn 1 inch below pocket.
14. Model Rocketry Badge: worn 2 inches below AMA Wings or 3 inches below pocket if no AMA Wings are worn.
15. First badge placed $\frac{1}{2}$ inch above name tag or ribbons and is centered horizontally. Additional badges placed $\frac{1}{2}$ inch above previous badge.

CADET FEMALE 1620 SERVICE DRESS

Note:

Officers: Hard ranks are on the coat and soft ranks are on the shirt.

Enlisted: Hard rank insignia must be on both shirt and blouse.

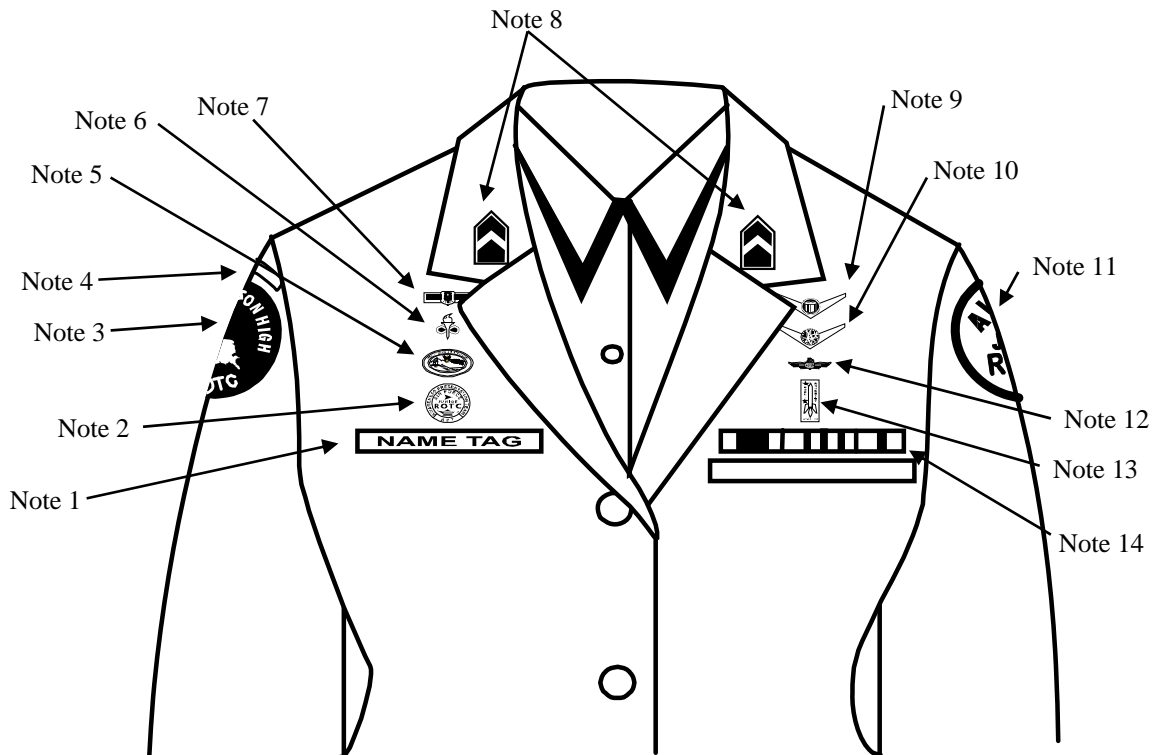

1. Name tag: authorized for wear and is to be centered on right side, even with to 1 1/2 inches higher or lower than the first exposed button.
2. Awareness Presentation Team Badge: see note 15.
3. Unit patch: center 1/2 to 1 inch below shoulder seam.
4. Shoulder tab: centered between unit patch and shoulder seam. If no patch, then 1 inch below shoulder seam.
5. Kitty Hawk Badge: see note 15.
6. Aerospace Education Foundation (AEF) Badge: see note 15.
7. Distinguished Cadet Badge: see note 15.
8. Grade insignia (officer or enlisted) worn on both lapels. Airman Basic wears lapel insignia on both lapels. Place insignia halfway up the seam, resting on but not over it. Bottom of insignia is horizontal with the ground.
9. Flight Solo or Flight Certificate Badge: see note 15.
10. Ground School Badge: see note 15.
11. AFJROTC Patch: center 1/2 to 1 inch below shoulder seam.
12. Academy of Model Aeronautic (AMA) Wings: see note 15.
13. Model Rocketry Badge: see note 15.
14. Ribbons: center ribbons resting on but not over edge of welt pocket. Wear 3 or 4 in a row. Wear all or some.
15. First badge placed 1/2 inch above name tag or ribbons (whichever is appropriate) and is centered horizontally. Additional badges placed 1/2 inch above previous badge.

CADET MALE BLUE SHIRT

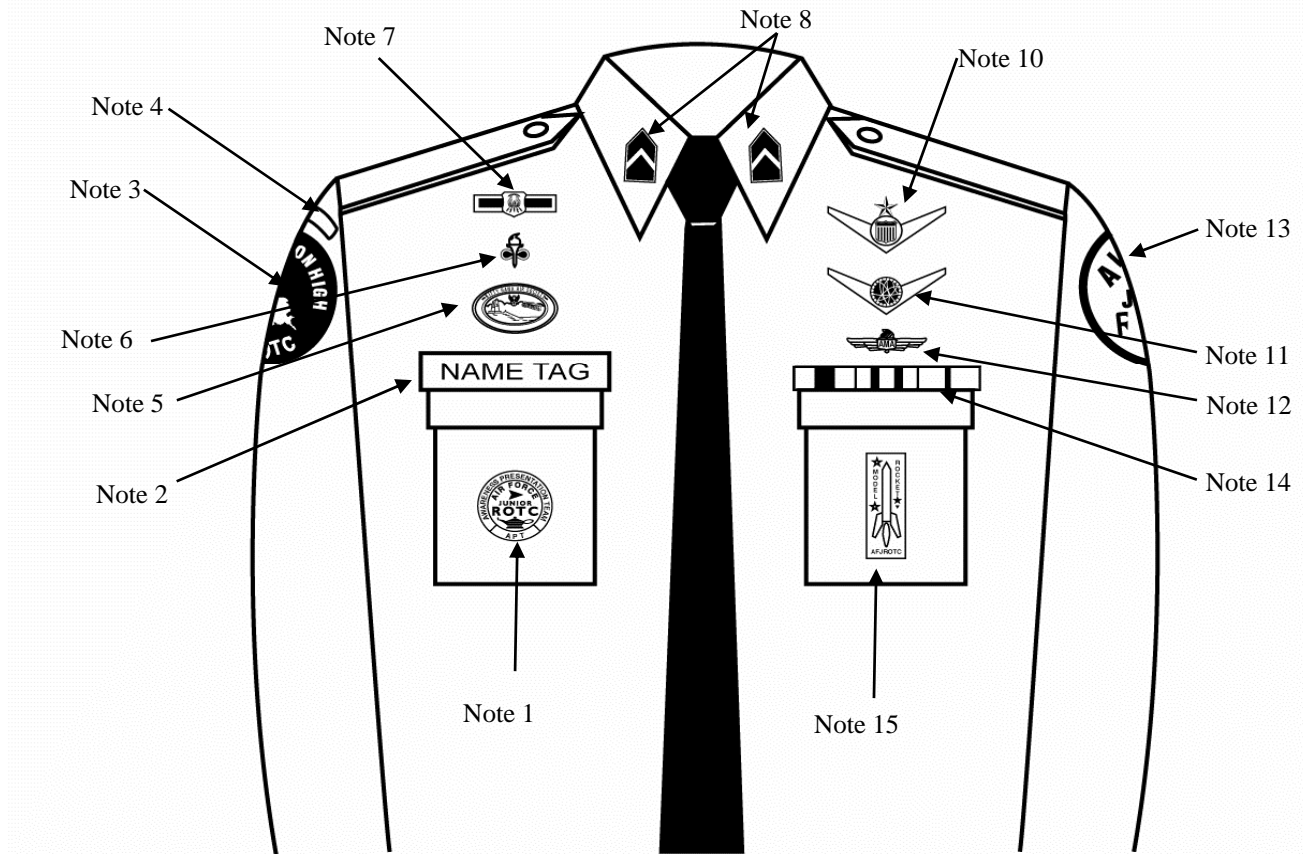

1. Awareness Presentation Team (APT) and Model Rocketry Badge are centered on the pockets on the appropriate sides as displayed above.
2. Name tag: authorized for wear and is to be grounded and centered over wearer's right pocket.
3. Unit patch: center 1/2 to 1 inch below shoulder seam.
4. Shoulder tab: center between unit patch and shoulder seam. If no patch, then place 1 inch below shoulder seam.
5. Kitty Hawk Badge: see note 15.
6. Aerospace Education Foundation (AEF) Badge: see note 15.
7. Distinguished Cadet Badge: see note 15.
8. Grade insignia (officer or enlisted) worn on both left and right collar, centered side to side and top to bottom. Enlisted rank's bottom point of torch points toward the point of the collar. Officer top point of rank aligned with point of collar. Airman Basic has no insignia of any kind on the collar.
9. (Officers only) When using officer cloth rank on epaulets versus miniature metal rank on collar, place as close as possible to shoulder seam.
10. Flight Solo or Flight Certificate Badge: see note 15.
11. Ground School Badge: see note 15.
12. Academy of Model Aeronautic (AMA) Wings: see note 15.
13. AFJROTC Patch: center 1/2 to 1 inch below shoulder seam.
14. Ribbons: ground and center on pocket.
15. First badge placed 1/2 inch above name tag or ribbons and is centered horizontally. Additional badges placed 1/2 inch above previous badge.

CADET FEMALE BLUE SHIRT

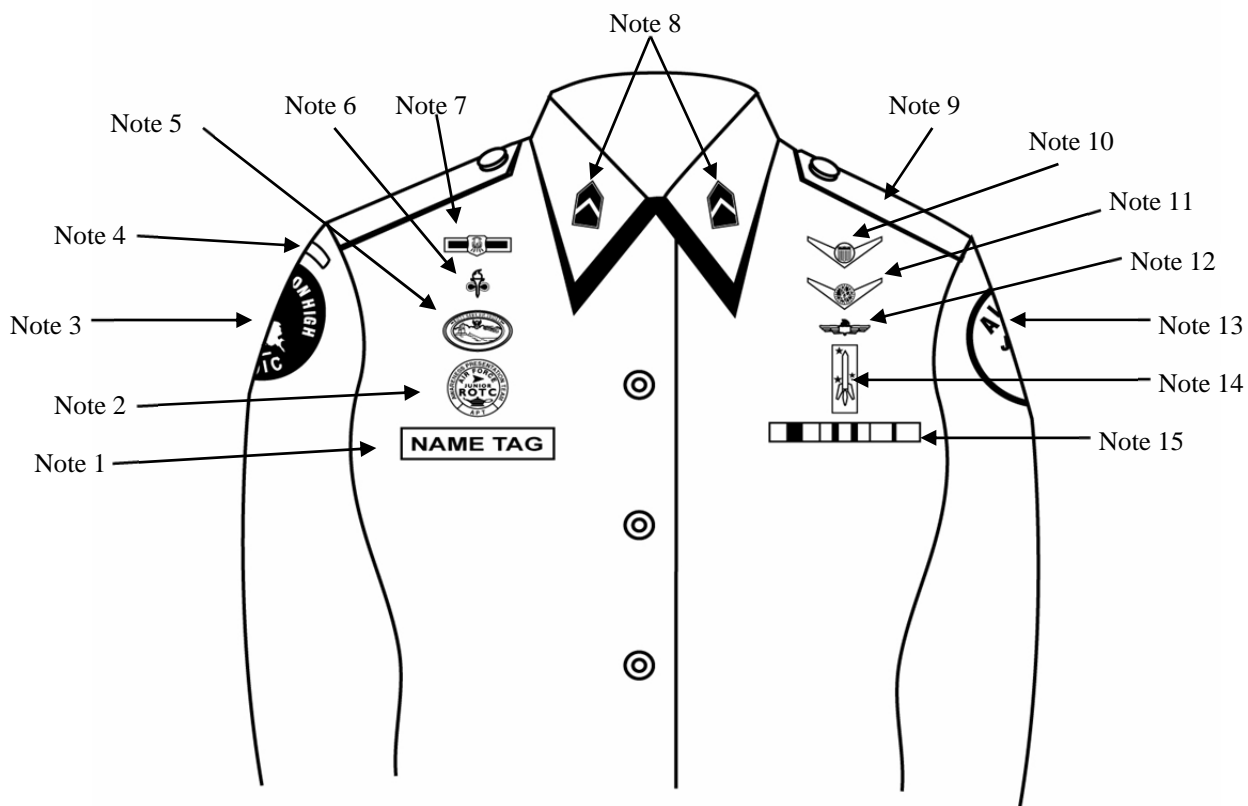

1. Name tag: authorized for wear and is to be centered on right side, even with to 1 1/2 inches higher or lower than the first exposed button.
2. Awareness Presentation Team Badge: see note 16.
3. Unit patch: center 1/2 to 1 inch below shoulder seam.
4. Shoulder tab: centered between unit patch and shoulder seam. If no patch, then 1 inch below shoulder seam.
5. Kitty Hawk Badge: see note 16.
6. Aerospace Education Foundation (AEF) Badge: see note 16.
7. Distinguished Cadet Badge: see note 16.
8. Grade insignia (officer or enlisted) worn on both left and right collar, centered side to side and top to bottom. Enlisted rank's bottom point of torch points toward the point of the collar. Officer top point of rank aligned with point of collar. Airman Basic has no insignia of any kind on the collar.
9. (Officers only) When using officer cloth rank on epaulets versus miniature metal rank on collar, place as close as possible to shoulder seam.
10. Flight Solo or Flight Certificate Badge: see note 16.
11. Ground School Badge: see note 16.
12. Academy of Model Aeronautic (AMA) Wings: see note 16.
13. AFJROTC Patch: center 1/2 to 1 inch below shoulder seam.
14. Model Rocketry Badge: see note 16.
15. Ribbons: Center, parallel with ground. Align with bottom of name tag. Or, if no name tag, align bottom of ribbons even with to 1 1/2 inches higher or lower than the first exposed button.
16. First badge placed 1/2 inch above name tag or ribbons (whichever is appropriate) and is centered horizontally. Additional badges placed 1/2 inch above previous badge.

CADET BATTLE DRESS UNIFORM (BDU) Male and Female

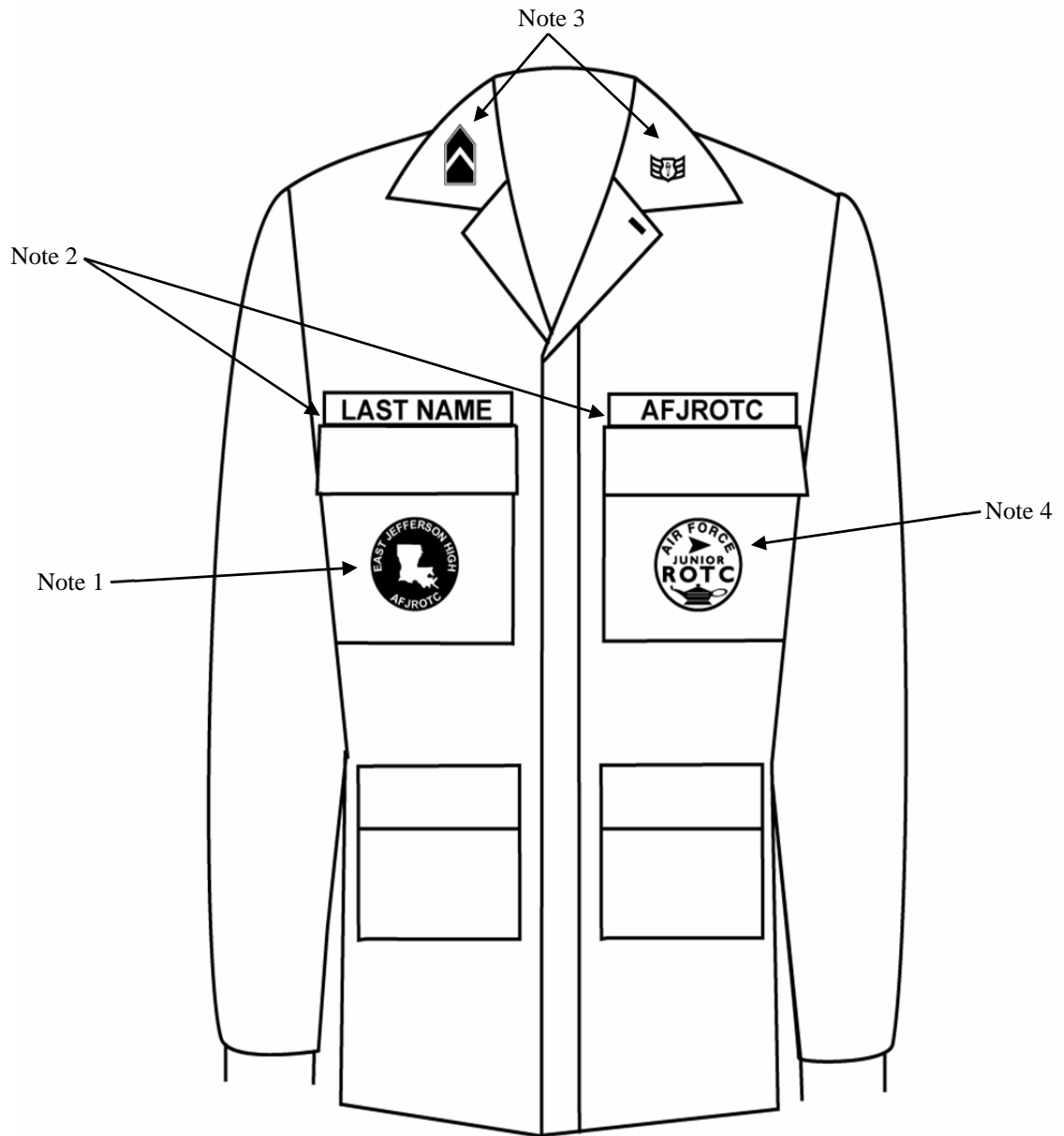

1. If worn, unit patch worn on right pocket and centered.
2. Tapes grounded and centered on pockets.
3. Grade insignia (officer or enlisted) is worn on both left and right collars, centered on collar and parallel with bottom of collar. Airman Basic has no collar insignia.
4. If worn, AFJROTC patch worn on left pocket and centered.

CHAPTER 9

Clothing and Equipment Account

1. Protecting government property is each cadet's responsibility. All uniforms (with the exception of the socks, shoes, and any corps t-shirts purchased separately) and books are equipment loaned to you by the United States Air Force. These items remain the property of the Air Force. Ropes are purchased by the cadet corps and must be replaced by the cadet if they are damaged. Each item of the uniform equipment must be accounted for at all times.
2. At the time you are issued your uniform and equipment, you will be required to sign a custody receipt form, and place your initials on each line for each individual item of uniform and equipment issued. After you receive your uniform, each item then becomes your personal responsibility. Cadets will be required to pay their dues when their uniform is issued to them at the beginning of the year. If you lose, destroy, or damage your uniform, you will be required to pay the cost of each applicable item.
3. One complete uniform with all accessories is issued to each cadet. It is most important that each cadet understand that all items of uniforms and equipment (except socks and any Corps T-shirt purchased separately) must be returned or paid for before the end of school year or grades and/or diplomas will not be awarded.
4. If a uniform item becomes unserviceable, for example torn, then you should turn the items in to your ASI/SASI as soon as possible. If the unserviceable condition is due to normal use, the item will be replaced at no cost as determined by the ASI. Items of clothing that do not fit properly should be exchanged. Whenever you notice a uniform problem or if an instructor points it out, it is **your** responsibility to get it taken care of **that day**. Failure to do this is poor time management and your grades will suffer. There will be no borrowing of items from Logistics, but there is a one-for-one exchange policy.
5. Lay the uniform out at home the night before inspection and get it ready. Find all the parts and keep them together weekly, so you always have your uniform ready for uniform day. Items that need to be repaired or exchanged will be taken care of **before** your next uniform day.

A final note: The duty uniform for the week is posted on the boards at the front and back of the classroom and uniform days occur weekly (unless otherwise instructed). It is the cadet's responsibility (not your parents) to have the uniform clean/out of the laundry on those days. "My uniform is in the cleaners" is an excuse that earns you a zero "0" on uniform wear for the week.

BE PREPARED!

CHAPTER 10

Progression, Organization Charts and Job Descriptions

1. Cadets will enter AFJROTC with the rank of Cadet Airman Basic and have no jobs. Cadets will progress through JROTC in both rank and job assignment.

(AS-I – all first year students regardless of class) By the end of a cadet’s first year, they should have been promoted up to Cadet Senior Airman. They will not hold a corps level job, however they may have held a flight level position. They should receive an assignment for the next school year as a technician. The highest performing AS-Is may have the opportunity to attend Summer Leadership School after their first AFJROTC year.

(AS-II) By the end of a cadet’s second year, they should have reached the rank of Cadet Technical Sergeant, but no higher than Cadet Master Sergeant. They should receive an assignment for the next school year as NCOIC or above, but this may be limited by the number of jobs available. Cadets who have not attended SLS the previous summer will have the opportunity to attend this summer. A few rising AS-IIIs may be selected to attend Cadet Staff leadership Lab (CSLL), join the command staff, and/or become flight commanders.

(AS-III) By the end of a cadet’s third year (could also be a second year cadet), they should have reached the rank of Master Sergeant or above, but this may be limited by the number of slots available. They should receive an assignment for the next school year on the command staff or as a flight commander, but this may be limited by the number of positions available. High performing cadets may be selected to attend CSLL.

(AS-IV) By the end of a cadet’s fourth year, they should have reached the rank of Senior Master Sergeant or above (Officers), but this may be limited by the number of slots available. The following charts reflect the TX-861st organization. The organizational chart breaks the functions of the unit down into specialized tasks. The job descriptions explaining responsibilities associated with each task are found on the corresponding pages. Each cadet should study all the job descriptions to gain a more complete understanding of jobs as they relate to the total unit mission. Also, communication between any necessary staff members to get the job accomplished must occur for the corps to be effective.

2. The organizational charts (Appendix R) reflect a “Chain of Command” by a solid line connecting the functions of positions. Information, guidance, and decisions flow down the chain of command in the form of oral and written instructions. Information and recommendations also flow up the chain of command, which are used by cadet leaders in decision-making. Information flow and coordination

between lateral functions is also necessary for efficient staff functioning (dashed line). Unless there is a free communication flow throughout the organization, the unit will not achieve effectiveness.

3. Authorized leadership positions are shown in the Unit Manning Document (UMD) found in Appendix B along with Job Descriptions in Appendix A.
4. Staff Officers will have a performance report filled out every six weeks by their superiors. They, in turn, will fill a performance report out for any junior officers or NCOs directly under them. This performance report will be taken into consideration for promotions and job opportunities.
5. Assignments for the following year will be made near the end of each spring semester. Cadets will have the opportunity to communicate assignment preferences for the following year by filling out a "dream sheet" prior to selection. The dream sheet allows cadets to rank order their assignment preferences. Volunteering for any job will not guarantee placement in that position. Likewise, not volunteering for a job won't eliminate that job from consideration. The instructors will make all job assignments using cadet inputs, job availability, cadet's interest/involvement in JROTC, and analysis of each cadet's strengths and weaknesses. At the end of the day, all assignments are made in the best interest of AFJROTC. Cadets are expected to place the needs of AFJROTC ahead of their own desires. The instructors will select a new Corps Commander and Vice Commander each semester from nominations provided by the current Group CC/CV. Cadets may hold each flight level position only one semester during their tenure in AFJROTC.

To become an officer and, consequently, hold an officer's position, cadets must attend SLS prior to assuming the position. Cadets may be selected for that position before attending SLS with the expectation that the cadet will attend in the preceding summer. Attendance at CSLL can substitute for the SLS prerequisite for promotions and assignments. However, attendance at CSLL is required to become Corps Commander or Vice Commander. It is also required for promotions up to Field Grade Officer (FGO) rank (i.e. C/Maj, C/Lt Col, C/Col). Waivers to this policy will be determined on a case by case basis by the SASI

CHAPTER 11

Cadet Personnel Boards

1. Cadet Personnel Boards will be formed to make recommendations concerning cadet promotions, cadet of the month, cadet of the quarter, and other personnel actions of the unit.

2. The cadet board will consist of a President, recorder, and other selected members as follows:

President: Group Commander or Deputy Commander

Recorder: Information Management

Members: Command Chief and any officer or NCO appointed by the CC

Instructor: For procedural matters only on disciplinary boards. If instructor is not available, the board meeting will be videotaped and the tape will be supplied to the SASI on completion of the meeting.

Rules: All discussions of the board and members meeting the board will NOT be discussed outside of the board meeting or instructors offices. Items discussed will not be shared with other cadets by any board member.

3. The board will be convened by publication of an order establishing the date, time, place, uniform required, and members required to set on the board. In most cases, the number of members on the board will be odd to prevent a stalemate in deliberation and the top ranking cadets involved with each situation will be placed on the board. The order will announce the purpose of the board and the name of the cadet(s) obligated to appear before the board. Cadets required to attend must initial the order, and if they are unable to report on the day ordered, a valid written excuse must be given to the Group Commander five days prior to the event.

4. Cadets appearing before the board will report to the President in uniform at the time and place announced in the order. Failure to report will result in serious disciplinary action.

5. Findings and recommendations will be submitted in writing to the Group Commander. After reviewing the report, the commander will add comments and any recommendations and personally deliver a typed report to the SASI.

6. One instructor will sit with the board and will act as an advisor on procedural matters concerning disciplinary boards only. They will not enter into the deliberations of the board.
7. Findings and recommendations of the board, after review and approval by the SASI, will be published by special orders and become part of the unit personnel records. Data will be included in the JUMS and WINGS databases as necessary.

Disciplinary Boards

1. Disciplinary boards are held when a cadet has violated rules or laws of a serious nature or after excessive warning of behavioral problems and unheeded corrective action measures. Procedurally, these boards will be held after a second written reprimand has been given to a cadet or by the order of the SASI or ASI.

Cadets must have been warned previously by:

- A. SASI or ASI
 - B. Cadet superior officer (in writing with a copy to SASI)
2. If problem still occurs, cadets may face extreme consequences (removal from the corps).
 3. Instructors will notify the Group Commander when a disciplinary board is needed to benefit the overall corps.

CHAPTER 12

The Cadet Promotion System

1. Promotion provides a constant challenge to individuals regardless of endeavor. It is a means to recognize individuals who meet the conditions and standards prescribed to be promoted. Within AFJROTC, cadet promotions also command attention and prestige by members of the corps. The insignia of rank is evidence of the ability and willingness of the cadet to accept responsibility, demonstrate leadership, accomplishments, and growth potential.
2. Promotions in the TX-861 Westwood High School AFJROTC unit are based on academic and leadership grades, co-curricular activity, responsibility, participation in teams, service, and organizational support. Promotions are also based upon cadet performance reports of past staff positions, the recommendations of commanding officers, and the general conduct of cadets.
3. The promotion system for TX-861 will follow the guidelines provided by Headquarters AFJROTC and AFROTC I 36-16.
 - a. **Permanent Grades:** All cadets will have a permanent grade equal to the number of years in AFJROTC satisfactorily completed, and will receive this permanent grade at the beginning of the second semester of each year, providing the individual cadet has made satisfactory progress during the year. Permanent grades may be withheld by failure to pay dues and/or any outstanding expenses. The permanent grade for first year cadets is Cadet Airman; for second year, Cadet Airman First Class; for third year, Cadet Senior Airman and for the fourth year, Cadet Staff Sergeant.
 - b. **Temporary Grades:** A temporary grade, not to exceed the grade for a given position on the Unit Manning Document (UMD), may be given to a cadet assigned to a specific position on the UMD. A cadet officer may be one grade over the maximum grade in a given position, if there is no one else to place in that position. Temporary Grade promotions will take place at the beginning of the year and at semester (With Change of Command), or within the year based on recommendation of Vice Group, Group, ASI, and SASI.
4. Cadet Officer promotions will be filled by third and fourth year cadets, unless insufficient qualified third and fourth year cadets are assigned. Normally, third and fourth year cadets will outrank first and second year cadets.

5. The following policies governing appointments and promotions apply to the cadets participating in the Aerospace Science program of Westwood High School:
- a. The Cadet Group Commander and Vice Commander will recommend to the SASI and ASI cadets to fill the positions, both officer and NCO, on the Unit Manning Document...to include recommendations for both Group Commander and Vice Commander positions. ALL NOMINATIONS will be presented with written justification to substantiate their selection. The SASI and ASI will have final decision on all positions.
 - b. The Cadet Group Commander and his/her staff will serve in designated positions until the second semester job rotation or until relieved by the SASI/ASI. Normally, cadets will stay in their designated positions at the semester rotation of Group Commanders. Cadets who are seen to not be capable of Officer or NCO positions will be removed from their position (recommended by Vice Group, Group, ASI, and SASI). Cadets who were not previously on staff, but have shown themselves worthy of an officer or NCO position and if a position has become available, may be placed into a position and promoted based on authorized grade in the UMD.
 - c. Promotion actions will be announced by the Cadet Group Special Orders published by the Cadet Information Management Officer with the approval of the SASI

6. The following is the criteria for permanent grade promotion:

- a. A cadet must attend at least two service projects in a given semester.
- b. All logistics and financial obligations must be cleared.
- c. Academic Scores: Each cadet must have passed Aerospace Science with a 75% or higher for the semester and must also have passed all other classes for the semester with a 75% or higher.
- d. Cadets must actively participate on (at least) one team.
- e. If a staff member is absent from his/her required meetings 3 times during the course of the semester (2 tardies equaling an absence), then he/she will not be considered for promotion.
- f. Disciplinary Action: Cadets who receive a written reprimand from a superior officer (2 counseling statements), are sent to the R.R.O.C., or suspended, receive an ISS, or receive 2 or more Saturday Detention Hall in a given semester, will be ineligible for promotion.

7. The following is the criteria for temporary grade promotion:

- a. If a staff member is absent from their required meetings 3 times during the course of the semester (2 tardies equaling an absence), then he/she will not be considered for promotion.
- b. Merits and Demerits: the balance for the semester must be positive for staff members; if it is not, then the cadet will not be considered for promotion.
- c. All logistics and financial obligations for the semester must be cleared.
- d. See criteria for permanent grade promotion for team, service, and academic requirements, as well as disciplinary status required for promotion consideration.

8. Promotions are based on the general “whole person concept” with consideration given to the following:

- a. AFJROTC Academic Achievement: How well does the cadet perform on quizzes, examinations, uniform wear, class projects, and presentations.
- b. Organizational Leadership: How well does the cadet function in positions of leadership? Does the cadet command respect from others? Does the cadet give proper consideration to subordinates? How does the cadet appear in uniform? Does cadet complete assignments/tasks on time?
- c. Co-Curricular Activities: To what degree does the cadet carry interest and enthusiasm beyond the classroom? Does the cadet participate and demonstrate excellence in all cadet activities?
- d. Responsibility: How does the cadet accept job assignments and responsibility? Does the cadet accept responsibility for the proper care of the uniform? Is the cadet always on time? Is staff work done?
- e. Service: To what degree does the cadet serve the school, community, and the cadet group? (If you have a job or are involved in other activities that interfere with service or other projects/practices, speak with the SASI/ASI to present your individual case.)
- f. Organizational Support: Does the cadet perform above and beyond normal duties? To what degree does the cadet participate on flag details, Drill Team, Physical Fitness Team, fundraising, parades, and other service projects and activities? The Personnel Officer will track the number of hours each cadet participates in Community Service events in addition to tracking participation in Special Teams. In this regard, scores may be awarded in these areas as follows:

The score for this category will be the number of events the cadet participated in divided by the number of total events. The percentage will be round to the nearest 10, and the zero dropped. For example... If a cadet participated in 5 of 8 events, this equals a 62.5% participation rate. This will be rounded to 60, the zero dropped for a final score of "6."

The community service score will be as follows:

18+ hours=10 points
16-18 hours=9 points
14-16 hours=8 points
12-14 hours=7 points
10-12 hours=6 points
9-10 hours=5 points
8-9 hours=4points
7-8 hours=3 points
6-7 hours=2 point
4-6 hours=1 point
Less than 4 hours=0 points

The Special Teams score will be awarded as follows.

10 points=Commander of a functioning team.
9 points= 90% of meetings and participation in 2 or more demonstrations or competitions
8 points=90% of meetings and participation in 1 or more demonstrations or competitions
7 points=75% of meetings and participation in 2 or more demonstrations or competitions
6 points=75% of meetings and participation in 1 or more demonstrations or competitions
5 points=90% of meetings
4 points=75% of meetings
3 points=66% of meetings
2 points=50% of meetings
1 point = 40% of meetings

Board Interview and Inspection: The Command Chief will award zero to 5 points for inspection and the Vice Commander will award zero through 5 points for the interview. The scores will be summed.

The candidate will wait outside the corps room until it is their turn. The candidate will use the following procedures:

1. Knock once. Wait until called in.
2. Proceed in the most expeditious route to a spot approximately 6 feet in front of the board chairman.
3. Come to the position of attention, salute and state : Sir/Ma'am, Cadet _____reporting as ordered.

4. Wait for the salute to be returned before dropping your salute. Remain at attention unless placed in another position, such as "at ease."
5. The board will ask you five questions. Answer them to the best of your ability. Do not lie or guess. If you do not know the answer, state the following, "Sir/Ma'am, this cadet does not know the answer but will find out and report back to you." (Note: Limit the use of this response, as you should know the answers to the questions you are being asked.)
6. The chairman will state, "Thank you for appearing before us, cadet. We have no further questions."
7. Come to attention if you are not already in that position, salute and state, "Sir, Ma'am, Request permission to be dismissed."
8. The chairman return your salute will reply, "Dismissed."
9. Drop your salute and exit the room in the most expeditious route possible

Skills Knowledge Test: The Personnel Officer will collect questions from Corps Senior Staff and devise a 20 question Test for the candidates. Candidate scores will be rounded down to the nearest 10, and the zero dropped to achieve final score.

The total score will be placed on the scoresheet and the board will determine whether or not promotion is recommended in accordance with the promotion recommendation sheet.

1. Following the promotion board, the board will rank order promotion candidates based on rank and board score and print the list of names.
2. For each rank, the chairman will draw a red line under the last name which can be promoted based on availability in the next rank.
3. The board will then compare the two candidates on each side of the red line and determine that last two candidates above the red line are more qualified than the first two candidates below the red line.
4. If correct, the chairman will sign the list, prepare promotion orders and send all information to the CC for validation.
5. If incorrect, the chairman will revise the list, add his/her signature, prepare promotion orders and send all information to the CC for validation.
6. The CC will recommend to the SASI that the list be approved as written or recommend changes.
7. The SASI will approve the final list.
8. Upon approval of the final list, the CC will sign the promotion orders.
9. The CC will send the signed orders to the flight commanders and personnel
10. The flight commanders will prepare promotion certificates, have the SASI and ASI sign, the certificates, and present the promotions in their next class period.
11. The flight commanders will update the cadet's personnel folder.
12. The personnel officer will prepare a new Alpha Roster and update WINGS.

As noted, actual promotions will be limited to current vacancies within the enlisted force structure. The force structure allows for many cadets at the lower enlisted ranks and fewer at the higher ranks. The force structure is as follows:

- Cadet Chief Master Sergeant (Maximum of 3% of Enlisted Corps)
- Cadet Senior Master Sergeant (Maximum of 6% of Enlisted Corps)
- Cadet Master Sergeant (Maximum of 12% of Enlisted Corps)
- Cadet Technical Sergeant (Maximum of 24% of Enlisted Corps)
- Cadet Staff Sergeant (Maximum of 36% of Enlisted Corps)
- Cadet Senior Airman (No Limitation)
- Cadet Airman First Class (No Limitation)
- Cadet Airman (No Limitation)
- Cadet Airman Basic (No Limitation)

Note that there is no limitation to cadets up to Cadet Senior Airman. Promotions to these ranks will be on a “fully qualified” basis. Promotions are guaranteed to all cadets who meet the standards. Above this level, promotion are on “best qualified” and “whole person” basis. The best cadets available will be selected for these promotions. Needless to say promotions to the highest ranks will be very competitive (See Appendix J for Enlisted Promotion Scoresheets).

Because of force structure limitations imposed by the greater honor and responsibility of higher rank, the AFJROTC rank structure, like the USAF rank structure, is pyramid shaped, with the low ranks being greater in number and high ranks being fewer (See chart below).

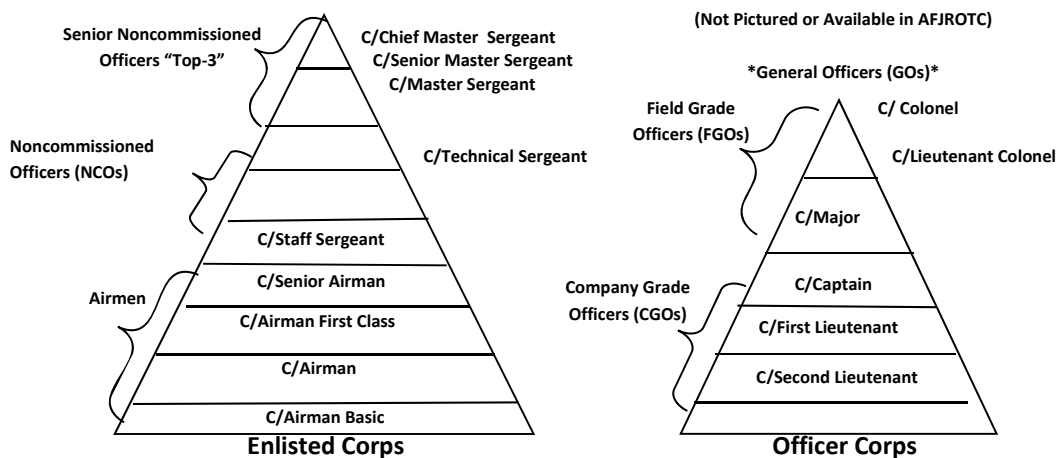

Officer Promotions and Rank Structure. Some cadets who have demonstrated a propensity for leadership and management will be selected to become officers within AFJROTC. No more than 20% of the corps may hold officer positions. Attendance at SLS is required to become a company grade officer (CGO). Attendance at CSLL is required to become a field grade officer (FGO). Waivers to this policy are at SASI discretion.

All cadets commissioned as officers will be commissioned as second lieutenants and be promoted each semester up to their highest PME-eligible rank based on satisfactory job performance. Officers must perform a flight commander function or serve on the command staff in order to maintain officer rank. Cadets selected as Corps Commander will assume the permanent rank of cadet colonel.

Example of Force Structure Assuming 100 cadets (Based on minimum viability enrollment)

Officers (20%)/Enlisted: Maximum of 20 officers /80 enlisted cadets.

C/CMSgt (3%): 3 cadets maximum

C/SMSgt (6%): 5 cadets maximum

C/MSgt (12%): 10 cadets maximum

C/TSgt (24%): 20 cadets maximum

C/SSgt (36%): 29 cadets maximum

No limit on number of cadets below this rank.

A corps "Alpha" Roster will be posted on the bulletin board which shows, current cadet rank, number of cadets in each rank, and how many and what type of promotions a cadet has had in the current academic year.

CHAPTER 13

Awards and Decorations

1. The Cadet Awards and Decorations Program recognizes achievements of AFJROTC cadets. Awards are earned by cadets who demonstrate academic achievement, leadership ability, and overall exceptional performance. The authority and guidance for these awards are contained in AFJROTC Instruction 36-2001. A summary of the most stringent criteria for the various awards is specified in Appendix F.

NOTE: Recommendations for the first four AFJROTC awards must be submitted to the Headquarters for review within six months of the incident and must include statements by victims or observers, newspaper clippings, or other material appropriate to validate eligibility.

2. **Local Awards:** (These awards are subject to change at discretion of Group Commander and SASI)
 - a. **Outstanding Rocketry Team Member:** This award is for distinguished participation and outstanding performance as a member of the Rocketry Team
 - b. **Outstanding Physical Fitness Team Member:** This award is presented for outstanding participation and a high score on the Air Force Physical Fitness Test
 - c. **Outstanding Saber Team Member:** This award is presented for distinguished participation and outstanding performance on saber team
 - d. **Outstanding Color Guard Team Member:** This award is presented for distinguished participation and outstanding performance on color guard
 - e. **Outstanding Drill Team Member:** This award is presented for distinguished participation and outstanding performance on drill team
 - f. **Westwood Principal's Award:** The principal presents this award to the cadet who demonstrates outstanding citizenship, behavior, academic excellence, and esprit de corps
 - g. **Most Improved Cadet:** This award is presented to a cadet whose behavior has most improved over the past year
 - h. **Outstanding Flight Commander Award:** This award is presented to the flight commander who has most excelled in their position
 - i. **Outstanding NCOIC Award:** This award is presented to the cadet noncommissioned officer who has performed in an excellent manner in his/her assigned position
 - j. **Outstanding Staff Officer Award:** This award is presented for performance on the cadet corps staff and for work done on group projects
 - k. **Outstanding Service Award:** This award is presented to the individual who has accumulated the most service hours over the year.
 - l. **Aerospace Academic Award:** This award is presented to the cadet with overall excellence in the Aerospace Science academic field
 - m. **Most Dedicated AS I:** This award is presented to an AS I cadet in our group who is the most dedicated to our cadet corps

- n. **Most Dedicated AS II:** This award is presented to an AS II cadet who is the most dedicated to our cadet corps
- o. **Most Dedicated AS III:** This award is presented to an AS II cadet who is the most dedicated to our cadet corps
- p. **Leadership Achievement Award:** This award is presented to the cadet who excels in uniform wear and academics in leadership class.
- q. **Most Motivated:** This award is presented to the cadet in our corps is the most motivated in terms of integrity first, service before self, and excellence in all we do.
- r. **Most Dedicated:** This award is presented to the cadet who has demonstrated exceptional dedication to the corps during the year
- s. **Corps Commander's Award:** This award is presented to a cadet who the corps commander recognizes as the most dedicated, motivated, and disciplined cadet.
- t. **Additionally, The SASI/ASI can nominate up to three rising AS-III or IV cadets to a weeklong Leadership Seminar aboard the USS Lexington through the Austin MOAA Chapter**

3. Cadet of the Month:

A Cadet of the Month will be selected for September through May yearly. The cadet will be selected by the Corps Commander with inputs from Group Deputy Commander, Squadron Commanders, Operations Officer, Flight Commanders and the Command Chief.

The following criteria will be used at a **minimum** to determine Cadet of the Month.

1. A uniform inspection average near or at 100% for each week of the previous month.
2. Participation one at least one team without missing a meeting during the previous month.
3. At least 10 merits and no demerits for the previous month
4. Attend at least one service project for the previous month and acquired a minimum of 3 service hours in that month.
5. Accomplishment of assigned duties during the month.

Cadet of the month will be announced in the cadet staff meeting on the first or second Thursday of the following month. The cadet of the month will have their name placed on a permanent plaque in the ROTC classroom and be eligible for Cadet of the Quarter.

4. Cadet of the Quarter:

A Cadet of the Quarter will be selected for each quarter. All candidates will be required to meet a cadet evaluation board appointed by the Corps Commander. In making their selection for cadet of the quarter, the board will consider the following factors

- a. Will be selected from the cadets of the month of the current quarter (no more than three candidates will meet the board for this award).
- b. Participation in corps activities such as teams, service hours, fund raising, and other activities.
- c. Effort put forth in Aerospace and Leadership classes.
- d. Behavior, self-discipline, and adherence to corps directives.
- e. Military bearing and conduct during the Board's review.

5. WESTWOOD "LETTER":

AFJROTC has been authorized to award the Westwood School Letter for AFJROTC participation. As with any other organization, only one jacket may be awarded during a cadet's high school career. Cadets who have already been awarded a jacket for another school activity can still receive an additional letter from the Corps. In order to qualify for this honor, a cadet must verify in writing points earned via his/her personnel file. Letters will be ordered and paid for by JROTC activity money only after SASI/ASI approval. The Jackets themselves must be purchased by the cadets. Slashes on the letter are authorized to recognize additional times lettering.

(NOTE: JROTC letter or jacket will be removed from cadets who discredit the corps.)

Since wearing the school letter indicates that the cadet has performed a service to the school, the community, or the corps, the following guidelines will be used in awarding the letter (All of these requirements are cumulative over previous years in ROTC, so not all of these requirements must be completed in your Junior year alone, but must be completed by the end.) :

1. Must have a JROTC grade average of 80 or higher.
2. Drill Team or Color Guard member with at least 10 performances in any team event and no unexcused absences.
3. Raise and lower the flag fifteen times as part of the flag detail. Or, if you are scheduled for only raising or only lowering, then you must accomplish 30 flag details. If you received demerits for not performing flag detail, you are not eligible.
4. Not miss more than two uniform wear days per year.

5. Additionally, cadets need 10 points from the criteria below:

- 1 point/semester for a leadership position
- 1 point for project officer of co-curricular activity
- 1 point for National Award recipients, per award
- 1 point for outstanding cadet
- 1 point for outstanding flight
- 1 point for PT excellence
- 1 point co-curricular activities ribbon
- 1 point for special projects as assigned by the SASI/ASI
- 1 point per service ribbon (maximum of 5)
- 2 points for per year of membership in Kitty Hawk Air Honor Society
- 1 point each for attending SLS, CSLL, or any other approved camp by the SASI/ASI
- 1 point for being a CTO/CTA at SLS or CSLL, or hold a leadership position at any approved camp by the SASI/ASI
- 1 point for earning Distinguished Graduate (DG) at any Leadership School
- 2 points for earning Honor Graduate (HG) at any Leadership School
- 3 points for service hours - exceeding 100 per semester

6. **TQS BERET:**

Awarded for completion of the full TQS process in Drill Team, Color Guard, or Rocketry. Completion of the process entails having all items in the training and certifying columns of your folder signed off, having passed with an 85% or higher on the team specification test, pass the Staff Qualification Test with an 85% or higher, as well as be passing all classes. For details see your team commander.

7. **KHAS Membership:**

Must be an AS-III or IV cadet with good moral character and leadership potential as well as maintain at least an "A" average in JROTC and a "B" average in all other courses. Therefore you are first eligible to be inducted at the end of the year awards banquet of your sophomore year. When you are selected as a candidate, you must complete the pledge program within the time constraints given. You must also maintain regular participation in AFJROTC activities as well as team membership.

8. TAP-IN:

To be eligible for induction into the order of the CLEAT and receive your taps, you must be a cadet in the AS-IV class and a member of the senior staff. You must also maintain the same requirements that are expected of the cadet officers as according to this cadet guide.

9. PROP and WINGS:

Upon authorization from the SASI, cadets are presented the standard chrome plated prop and wings device for wear on their Unit Baseball Caps. The 861st SASI has implemented this device to distinguish cadets for their hard work and dedication, and to purposely identify them. This device is the same device Senior ROTC POC cadets will be issued upon satisfactory completion of Field Training and entrance into the Professional Officer Course in conjunction with promotion to cadet officer rank. At the US Air Force Academy, cadets who are direct descendants of members of the Army Air Corps, Women Air Force Service Pilots, have a parent with at least 20 years of military service, have a parent that participated in combat as a member of any U.S. military service, or a parent that died in the line of duty are authorized to wear the similar gold and silver prop and wings device. The TX-861st SASI extends this offer to TX-861st cadets meeting these criteria. To be eligible for induction into this fraternity and receive your wings at the Tap-In Ceremony, you must be a cadet in the AS-IV class and a member of the senior staff. You must also maintain the same requirements that are expected of the cadet officers as according to this cadet guide.

CHAPTER 14

Classroom Procedures

Opening Procedures.

1. Cadets will arrive to class on time.
2. Prior to the tardy bell, cadets will place all material needed for the course on the desk in front of them. (This includes any homework, writing utensils, paper, notebook, clicker, etc.)
3. All items not needed for class are to be placed under the desk.
4. Element Leaders will issue course Textbooks.
5. Cadets will come to the position of parade rest.
6. When the tardy bell rings, the flight commander takes control of the flight and calls the room to attention.
7. The Flight Commander will lead the pledges of allegiance to the US and Texas state flags.
 - a. All cadets will audibly recite both pledges unless exempted by the SASI. SASI will grant exemption IAW school policy. This exemption will be noted in the cadet folder.
 - b. During 2nd period, the pledges and announcements will be led over intercom by JROTC cadets.
8. The Flight Sergeant will take attendance from Element Leaders and report to the instructor.
9. Any tardy cadet will salute the flight commander (or instructor) and request permission to join the flight by saying, "Sir/Ma'am, Cadet ____ requests permission to join the formation."
10. When permission is granted, cadet(s) will expeditiously place unneeded materials under the desk, gather needed materials and report to the instructor.
11. The Flight commander will direct the guidon to be posted by saying, "Guidon bearer, post guidon."
12. The guidon bearer will take his/her flight guidon and place it in the flag holder in the classroom. He/she will then face the flight commander, come to attention, salute and report, "Sir/Ma'am, ____flight Guidon Posted."
13. The flight commander will return the salute and state "Return to your seat." The guidon bearer will return to the position of attention behind his/her seat.
14. The flight commander will put the flight at parade rest.
15. The Flight Commander will make the corps announcements and call upon the various representatives for reports.
16. When complete, the flight commander will call the room to attention, approach the instructor of the day, salute and turn control of the flight to the instructor, "Sir, the flight is prepared for instruction."
17. The instructor will return the salute and reply, "Thank you, please take your seats."
18. The instructor will direct the flight, "At ease."
19. The entire flight will participate in class until control of the flight is returned to the flight commander.

NOTE: Classroom questions are encouraged on the topic of discussion, and cadets having questions will raise their hands to be recognized. **It is the cadet's responsibility to inform instructors when they cannot make a scheduled assignment. EXAMPLE: Wear of the uniform on uniform day.**

NOTE: When leaving the classroom for an outside activity or drill, flight commanders will call the flight to attention, have them "post" and give a "column of files." The flight will march outside, mark time before reaching the curb. The flight commander will have the flight "Halt", "Fall Out" and form them into flight formation outside. When returning to the classroom, the first male cadet will hold the door open for all and the flight will fall in at the position of attention in the classroom.

Closing Procedures.

1. Prior to the bell, the instructor will direct the flight commander to prepare the flight for dismissal by saying, "Flight Commander, the Flight is yours." Or "Prepare your flight for dismissal."
2. The flight commander will call the room to attention and say "Flight, prepare for dismissal."
3. Flight members will put away their belongings, clickers and textbooks, clean up the corps room and come to the position of parade rest behind their seats.
4. The flight commander will call the flight to attention
5. The flight commander will direct the guidon bearer to retrieve the guidon, "Guidon bearer, retrieve the guidon."
6. The guidon bearer will retrieve the guidon and return it. He/she will report to the flight commander, salute and say "Sir/ma'am, guidon is retrieved."
7. The flight commander will dismiss the flight by stating, "Flight, Dismissed" or "Flight, dismissed at the bell." (Note. The bell does not dismiss the flight; the flight commander does.)

NOTE: Food will not be visible and will not be eaten in the classroom during normal class periods. If food is brought from home and eaten in the classroom during lunch, the cadet(s) will be required to clean the tables after eating. **Eating in the staff room or classroom is a privilege, not a right.** Failure to keep the AFJROTC area and classroom clean will result in a loss of that privilege by cadet members who fail to clean up after themselves. **No cafeteria food may be brought into the AFJROTC class/staff room, Also, no food shall be eaten in the hallway or anywhere else besides the cafeteria. THIS INCLUDES IN THE IMMEDIATE VICINITY OF THE BUILDING.**

General Corps Rules

1. All cadets are responsible for complying with and enforcing JROTC rules.
2. As previously discussed, cadets will comply with all school rules.
3. Reminder, cadets will come to each class prepared for the day's lesson. Being prepared means having a pen/pencil, paper, cadet guide, and appropriate uniform for the day's activities.
4. As noted, cadets will not eat, drink (except for water) or chew gum, in the AFJROTC classroom.
5. Cadets will not sleep, lay their head down or prop their head up with their hand(s) in class unless directed by the instructor.
6. Military headgear will not be worn indoors. Gentlemen will not wear hats of any kind indoors.
7. Cadets will ensure the classroom and cadet areas are left neat before departing (including ensuring trash is taken out of Logistics at the end of the day for disposal by custodians).
8. Logistics personnel will not loan uniform items. Cadets must purchase lost/forgotten items.
9. Cadets will not sit on tables or desks. Cadets must keep all four legs of their chairs on the floor.
10. Cadets will speak to each other with respect. Cadets will not engage in rudeness or disrespectful behavior towards anyone.
11. Cadets will not use foul language or engage in vulgar conversations.
12. Cadets will not have electronic devices of any kind available to them during the school day without express permission for each occurrence. Electronic devices may be used before 0905 and after school (1610) if they do not interrupt other activities taking place.
 - a. Offending electronic devices (phones, Ipods, Ipads, etc.) will be confiscated unless it is a BYOD for specific pre-authorized use in class. Violators will have the option of retrieving their items from the AP office in accordance with school policy or reclaiming them from a JROTC instructor after class in accordance with the JROTC policy in effect.
13. Cadets will not write on any board without the permission of the instructors or Information Management Officer.
14. Cadets will not engage in PC (physical contact) or PDA (public displays of affection).
15. Cadets will not interact with cadets in another class while class is in session without the express permission of the instructor.
16. Cadets will participate fully in all activities. Cadets will not be excused from class to work on another class unless there is no reasonable alternative AND the request is made directly by the other teacher to the JROTC instructor. The JROTC instructors have final say.
17. If we ask other teachers to release you from their class for JROTC purposes, that teacher has final say about whether or not you may be released.
18. Cadets will not leave the classroom, while the flight is under the control of the flight commander or instructor of the day without their permission. (This includes, but is not limited to, getting water, going to the latrine, and talking to another instructor.)
19. Cadets will not be excused from PT for any reason other than a doctor's note. Playing in other sports is not a legitimate reason. Your coach must personally request that you be allowed to miss PT. This will only be allowed on game days and the JROTC instructors have final say.
20. While in the corps room, the corps hallway or at any other JROTC function, cadets will address each other by Mister _____ Miss _____, Cadet _____ or their rank. The exception to this is during social functions.

CHAPTER 15

Staff Meeting Procedures

1. The TX-861 Group Commander will hold weekly staff meetings throughout the school year, usually each Thursday at 0800.
2. Meeting will be held in the classroom unless otherwise specified.
3. There are no excuses for absences or tardies unless the Group Commander or Deputy Group Commander approves it in advance. If a cadet acquires 3 unexcused absences for any meeting in the course of the semester (2 tardies equaling an absence), that cadet will not be considered for promotion.
4. The staff meetings provide the opportunities for face-to-face communication between the commander and his/her staff. It is a means for group problem solving and allows the cadet staff to participate in unit planning. It is a time for the discussion of issues and decision making.
5. The following procedures apply:
 - a. The GP/CC (or highest ranking officer in his/her absence) will conduct the meeting.
 - b. The GP/CC will prepare the agenda and ensure that all items on the agenda are being addressed at the meeting.
 - c. The Personnel Officer will take attendance and issue demerits for staff members not present and without approved excuse.
 - d. The Information Officer will serve as a recorder and prepare a report of each meeting detailing decisions reached, actions taken, assignments made to staff members for further action and other discussion. The report will be made available immediately following the meeting so that all cadets can be briefed during the class-flight discussion time the same day. Meeting minutes will be posted on the board in the classroom for all who are interested to read. A copy will be given to the SASI/ASI
 - e. All staff meeting members must have notes prepared and must take notes when needed for the staff meeting.
 - f. The CC will follow-up with the assistance of the CV to ensure that actions directed during the staff meetings are accomplished by the responsible staff member/team.
 - g. ALL members are responsible for communicating/collaborating matters with their peers.

CHAPTER 16

Cadet Staff Office

General Rules and Procedures:

1. Cadets who are not on staff must knock once and wait to be acknowledged before entering; and while in the staff office, non-staff members must be either using the phone, or doing staff work.
2. Only cadet staff members are allowed to keep books and other materials in their assigned drawers in the staff office.
3. When an instructor or cadet officer of a higher rank enters the staff room, it will be called to attention regardless of the time of day or how many people are in the room.
4. Personal belongings must be secured by shutdown. Any extraneous items left in the staff room at the close of business will be placed in the Lost and Found.
5. Staff members may use electronic devices within the staff room only. This is a staff privilege and not extended to anyone not on staff.

Cleanliness:

On the whiteboard in the staff office there will be a Monday through Friday list of who is in charge of clean up for each day. It is the assigned cadet's responsibility to ensure that the staff room is clean before shutdown. All trash should be picked up, staff materials left out get put in Lost and Found, and all electronic devices should be turned off. Cadets who bring their food may eat lunch in the staff office or in the classroom. No cafeteria food may be brought into the ROTC building from the main school. **NO EATING IN THE HALLWAYS OF THE BUILDING, OR THE IMMEDIATE VICINITY OF THE BUILDING.** Cadets will use the spray cleaner and paper towels to clean up after they finish eating. If the trashcan is too full, take the trash to the dumpster. Failure to keep the staff room clean or follow these rules will result in loss of staff office privileges for ALL STAFF.

Cadet Staff Phone:

1. Cadet staff coordinating ROTC events may use the phone to coordinate events with the instructors' permission during the school day.
2. Cadets and other students will not use the ROTC phone to call parents when they are sick. If sick, go to the nurse and call home from there. Disregard of this rule will cause the loss of the staff room phone.
3. Any cadet may use the phone to call for a ride after school. Limit phone calls to 2 minutes.
4. The phone will be answered with the following: "Westwood AFJROTC staff room, cadet _____ speaking, how may I help you?"

CHAPTER 17

Instructor Office and Logistics Area

1. The SASI and the ASI practice an “Open Door Policy”. Cadets are invited and encouraged to visit instructors in their office anytime the instructor is present. However, all cadets are required to knock once and wait for acknowledgement from the instructor before entering. If the instructors are in conference or have another cadet or parent in the office, expect to wait until that meeting is finished before you knock and are acknowledged. Cadets should not expect to be allowed to miss class or become tardy based on instructor discussions.
2. Visitors are not allowed in the ROTC area unless they have signed in with the main school office (**school policy**) and the instructors must be notified that they are present. Former cadets are encouraged to return to Westwood ROTC and share their experiences from life after high school.
3. Cadets will not enter the logistics area without a reason or approval (refrigerator use is approved). There is no borrowing of uniform items, only one for one exchange or purchases. No cadet, other than posted, is allowed beyond the “restricted section” unless escorted, one at a time.
4. Logistics Officer, Logistics NCO, Deputy Commander, Group Commander, or an Instructor must be present before cadets enter the restricted section.
5. Like the staff room, cadets must knock on the door and wait for acknowledgment from one of the persons listed above.
6. Cadets are not to pass behind the logistics desk unless permitted by one of the persons listed above.

Refrigerator:

- a) Any cadet may use the refrigerator but must label their items.
- b) Anything not labeled is considered available to anyone.
- c) The refrigerator will be kept clean and old food and drink will be discarded every Friday.
- d) The Logistics Officer must develop a signup sheet for weekly refrigerator cleanup duties.

CHAPTER 18

ORDERS

1. Orders, either written or verbal, are directives handed down by superior officers in order to achieve a mission that needs to be followed implicitly. Disobeying an order is grounds for disciplinary action.
2. Orders are composed of four main components: Situation, Standing Order, Transportation, and Desired Outcome.
 - Situation: The OIC (Officer in Charge) will record any relevant background information on the event as well as the reason for the required/requested presence of the TX-861 at the event.
 - Standing Order: OIC will clarify the logistical details of the event (i.e. who, what, when, and where)
 - Transportation: The OIC will document any transportation information involved with the event's execution.
 - Desired Outcome: The OIC will provide input as to the expected outcome and how this may improve morale within the corps and present a positive image to the community.
3. Orders need to include the proper signature blocks for the required superior officers (Note: The SASI and ASI sign every order). Any order for an event concerning any of the squadrons within the corps needs to be signed by the respective squadron commander, the vice group commander, and the group commander.
4. Order requests must be submitted to info management for review. Info management will write orders and submit them up the chain for posting.
5. The written orders template is available on any of the ROTC staff room computers. The order number in the upper right hand corner needs to be updated for each order. **Written orders need to be posted on the orders board in the classroom at least five days prior to the event for the required cadets to initial them.**
6. If a cadet has a valid reason as to why they need to be excused from the event, they must submit it (in proper military letter format) to the OIC at least five days prior to the event.

CHAPTER 19

Admission, Transfer, Completion, and Disenrollment

1. **Admission:** To be eligible for participation in the AFJROTC TX-861st program, a student must be:
 - a. Enrolled in and attending a regular course of instruction at Westwood High School.
 - b. Citizen of the United States or alien lawfully admitted to the United States for permanent residence.
 - c. Physically fit to participate in AFJROTC training. A cadet is considered physically fit if he or she is qualified for the Westwood Physical Education (PE) Program and capable of marching and standing during class time.
 - d. Selected by the SASI in coordination with the Principal or a designated representative who will ensure that acceptable standards are met by enrolled students.
2. **Transfer:** Students who transfer from Army, Navy, Marine Corps, or other Air Force JROTC units may receive full credit for training already received with appropriate documentation from their previous unit. Cadets will be interviewed and a transfer of rank held in another service program will be determined by the SASI after records are received from the previous unit. Cadet Officers transferring from other units are not automatically guaranteed to be selected for staff jobs and, by consequence, may have to relinquish temporary rank until a staff job has become available.
3. **AFJROTC Course Completion:** There are two types of certificates that may be awarded to AFJROTC cadets who complete the AFJROTC program: the “Certificate of Training” and the “Certificate of Completion.”
 - a. **Certificate of Training:** Presented to cadets of good standing who have completed **two years** of the JROTC Program. The cadet must graduate from high school or have transferred to another school. With the Certificate of Training, a cadet may be excused from one academic semester of the General Military Course (GMC) in the senior (College level) ROTC Program. This privilege must be arranged with the Professor of Aerospace Studies (PAS) at the time of enrollment in the college or university.
 - b. **Certificate of Completion:** Presented to cadets of good standing who have completed at least **three years** of the JROTC program. Cadets who have this certificate in their possession when enrolling in a senior ROTC program or enlistment in the Armed Forces of the United States may gain benefits offered by successful completion of the AFJROTC program.

I. The Certificate of Completion may excuse the cadet from one year of the General Military Course in the Senior ROTC Program. This privilege must be arranged with the Professor of Aerospace Studies (PAS) at the time of enrollment in a college or university.

II. If the graduating cadet elects to enlist in the Armed Forces of the United States, the Certificate of Completion may provide for promotion from pay grade E-2 to E-4, depending on the individual service. Enlistment in the United States Air Force may result in E-3 rank, equivalent to the grade of Airman First Class. This promotion at the time of enlistment can provide for an immediate monetary benefit (higher pay) and will place the cadet ahead of all other enlistees who enter at the same time.

NOTE: These certificates are not awarded automatically based upon time in AFJROTC and academic grades. Consideration is given to the total performance and achievement as a member of the Corps. It is possible to complete the AFJROTC course for academic credit, but not be considered to have met the "Whole Person Concept" requirements for the award of a certificate. Final determination will be made by the SASI/ASI.

4. **Disenrollment:** A cadet may be **disenrolled** for any of the following reasons:

- a. Failure to maintain acceptable course standards such as proper grooming standards, and proper uniform wear. NOTE: Failure to wear the uniform twice in a six weeks grading period will result in a failing grade. Not wearing the uniform three times in a semester is cause for failure for the semester and removal from AFJROTC.
- b. Inaptitude, indifference to training, disciplinary reasons, or reasons involving undesirable traits of character. For example: breaking school rules, fighting, etc.
- c. Failure to maintain a passing grade in AFJROTC.
- d. Failure to remain enrolled in Westwood High School.
- e. Written parental permission at semester time.
- f. Any other reason deemed appropriate by the Principal and the SASI.

CHAPTER 20

Computer Guidelines in AFJROTC

No games will be played on any computer at any time.

1. The computers in the staff room, classroom, and logistics may be used before and after school by cadets.
2. The ESO and SASI will be notified if any viruses are detected on the ROTC area computers. The instructors must also be aware of any computer damage from cadets.
3. The cadet staff room computers are for the use of the cadet staff members only. Other cadets needing a computer will use the library. If all are being used then the cadet must obtain the SASI or Group Commander's permission before the staff room computer will be used.
4. It is the responsibility of the highest ranking officer in the room to report any defiance of these guidelines up the Chain of Command.
5. Instructors' computers and the instructor laptop in the classroom are off limits to all cadets unless otherwise directed by an instructor.
6. **Internet will be used according to the school rules.**

NOTE: Computers are being monitored by the district - any illegal activity, when detected, will be traced to the originating machine. **Any misuse or failure to follow the computer use guidelines will result in loss of computer privileges and staff room privileges for 3 weeks.**

CHAPTER 21

Hazing Policy

1. Hazing of cadets is strictly prohibited. **Any type of physical abuse, verbal slurs, abuse of race background, or mental abuse will not be permitted at all.** The TX-861 AFJROTC has a “Zero Tolerance” attitude to harassment of any kind. Hazing could be considered as... “To harass or persecute with meaningless, difficult, demeaning task.” In the Air Force hazing is: ... “an unauthorized assumption of authority by one military member over another that results in cruelty or humiliation.” **Neither will be tolerated and ALL Round Rock ISD Student-Parent Handbook and Code of Conduct rules will be adhered to and enforced.**
2. **Think before you act or say something (verbal, written or electrically). You must consider how the other individual cadet will perceive your action or words. Remember, once something is transmitted electronically, control over that item is immediately relinquished. Also, if you are relying on written communications, there is no feedback loop so there is a high probability of confusion and/or misinterpretation of your message.**
3. If a cadet feels that he or she is being harassed in this or any other way, please feel free to discuss this with the instructor in the privacy of the office. If the group staff officers witness any hazing, they will immediately notify the SASI in the office where other cadets cannot hear. After a report is made, an immediate investigation will begin.
4. Instructors will review this policy annually and brief all cadets at the beginning of each semester on this policy. These briefings will be documented in the instructor files.

CHAPTER 22

Evaluation and Grading System

1. The Aerospace Science and Leadership program is cadet-centered. Learning and developing new life skills are the program objectives which are learned through many different activities during class time and at AFJROTC events. You will be evaluated on how well you have learned and developed new skills in several ways. You will have academic evaluation by written testing in both classes. There will also be tasks based on performance such as oral presentations and reports. You will be required to demonstrate proficiency in drill and ceremonies, and you will be graded on your ability in wearing the uniform correctly and in accordance with the uniform guidelines once a week.
2. Your "Aerospace Science" grade is made up of three parts -- your score in Aerospace, your score in Leadership and your Wellness score. Since Aerospace studies are 40%, Leadership is 40% and Wellness is 20%, we compute your final 6 weeks grade in the same ratio. That is, 40 percent will be due to Aerospace achievement, 40 percent will be due to your achievement in Leadership and 20 percent will be due to your participation in the Wellness Program. For example, your six weeks score is 90 in Aerospace, 80 in Leadership and 100 in Wellness. We arrive at your final grade as follows:

EXAMPLE: AS 90 x 40% = 36
 LE 80 x 40% = 32
 Wellness 100 x 20% = 20
 Total = 88 grade / six weeks

3. Late Work: Late work loses 10 points per day. Cadets missing class due to an excused absence will be allowed a period of time equal to the number of days absent to make up missed work. When you are absent for any reason, it is your responsibility to ask your instructors for work missed when returning to school.
4. Leadership Grade:
 - a. Cadets who fail to wear the uniform on the designated uniform day will receive a "0" for that uniform grading day. Cadets who continue to fail to wear the uniform on assigned uniform days for any three times in a semester receive both a failing grade and will be recommended for removal from AFJROTC. Cadets may make up a missed uniform day with prior approval of the ASI. If a cadet has missed uniform wear and has not made it up for the week, he/she will not be allowed to participate in sports on Friday.
 - b. Cadets who are absent from school on a uniform day will not receive a grade for that uniform day. Cadets who have many unexcused absences on uniform days may receive a failing grade for the semester and/or be considered for removal from AFJROTC.

CHAPTER 23

Merit/Demerit System

1. **Merits:** Merits are positive reinforcement. Merits should be considered bonus points for making positive contributions to or exceeding corps standards. Cadet may earn merits either individually or as a group (element or flight). Two merits are given for attending team meetings and operations meetings. Merits benefit a cadet in many ways. One way is that merits offset or take away demerits.
2. **Demerits:** Demerits are negative reinforcement. Demerits are given for not achieving the standard or for not fulfilling responsibilities. Any cadet who does not meet the high standards of conduct, discipline, and performance expected of AFJROTC cadets can expect to receive demerit points. Two Demerits are given for not attending team meetings, and Operations Meetings. Demerits can be given to cadets either individually or as a group.
3. **Effect of Merits/Demerits:** Merits/demerits affect a cadet in the following ways:
 - a. Merits
 - They could help you get promoted
 - They may positively affect your flight standing in inter-flight competition
 - They may be considered when evaluating for awards such as Locals or Nationals.
 - b. Demerits
 - They will negatively affect your flight standing in inter-flight competition
 - They will be considered when evaluating cadets for awards
 - They may prevent you from participating in outdoor sports day
 - They may prevent you from attending a CIA trip
4. **Merits and Demerits May Be Assigned By:**
 - a. SASI or ASI
 - b. Group Commander or Deputy Group Commander
 - c. Squadron Commander (to members of their squadron)
 - d. Flight Commander (to members of their flight)
 - e. Operations officer and team commanders (to members of their respective teams)
 - f. Any staff officer to a cadet of lower rank

5. **Merits Review:** Team merits and demerits are given to the C/Operations Officer for review and then forwarded to the SASI or ASI. The SASI or ASI approves all merits/demerits. The merit and demerit form also allows for appeals.
6. **Procedures for Merits and Demerits:** Merit and demerits will be awarded using the merit/demerit form and or the mass merit/demerit form. Receiving or giving merits is expected; receiving demerits is not expected. The goal is for cadets to learn and not receive demerits. Completed forms will be given to the Squadron Commander then Deputy Group Commander for review and then to the SASI or ASI for final review. Finally, the top half of the merit/demerit form will go to the recipient and the bottom half will go to the Awards and Decorations Officer for tracking purposes. Merits and demerits are applied to the class grade for the six-weeks and then start over the next six weeks.
7. **Demerit Appeals:** If a cadet feels that he/she has been given the demerits unfairly, that there are extenuating circumstances, or that the amount given is excessive, he/she can appeal them. Write the reason(s) or circumstances for the appeal on the bottom of the Merit/Demerit Form and submit it to the deputy group commander, who forwards it to the group commander. The group commander will review the circumstances, make an impartial judgment and then return the form to the cadet with his or her decision. The group commander will notify the deputy commander to adjust the tracking system, if needed. If the cadet still feels that he/she has not been treated fairly, he/she then can further appeal to the SASI or ASI.
8. **Record Keeping:** The deputy group commander will ensure the SASI or ASI approves all merits and demerits before recording them to cadet records. The deputy commander will maintain records of all merits/demerits. These will be updated each week and posted on the bulletin board at the end of each 6 week grading period. Cadets should promptly review their totals for accuracy before the merits and demerits are used to determine the above listed actions. The deputy commander will keep cumulative totals for each six weeks period and provide these to the SASI in writing. Also, tracking of total merits and demerits for the semester will be done for promotion and non-participation in trips. Merits/demerits will not carry over from one six weeks to the next.
9. **Limited Factors:** Any cadet who allows his merit/ demerit balance to reach negative 15 in a given six weeks will be referred by the Deputy Commander to the SASI for consideration for removal from field trips and other activities. Any cadet who allows his merit/ demerit balance to reach 30 in a given semester will be referred by the deputy commander to the SASI, for consideration for demotion or removal from the program.

MERIT POINTS (Examples of some typical merit assessments):

1.	Flag detail replacement	2
2.	Special academic report	1-5
3.	Tutoring other cadets (per 15 minute session)	1
4.	Outstanding classroom participation	1
5.	Exceptional performance at drill	1
6.	Exceptional shoe shine	1
7.	Sharpest cadet at Inspection	1-5
8.	Team practices	2
9.	Candidates for Outstanding Cadet of the Quarter	1-10
10.	Community service	1-20
11.	Recruiting activities	1-8
12.	Special tasks (Per each hour of work)	1-2
13.	Outstanding performance	1-5

DEMERIT POINTS (Examples of some typical demerit assessments):

1.	Disrespect (for example to instructors; to your flight commander)	1-10
2.	Insubordination	1-10
3.	Sleeping or not paying attention in class	1-5
4.	Uniform improperly worn	1-5
5.	Failure to perform flag detail	2
6.	Forgetting uniform items on uniform day	2-4
7.	Not bringing book, paper, or pencil to class	1-2
8.	Cursing or obscene language	1-5
9.	Chewing gum/eating candy in class	1-2
10.	Discourteous or improper classroom behavior	1-3
11.	Littering classroom/cadet staff area	2-5
13.	Failure to meet scheduled formation	1-5
14.	Moving/talking in formation (w/o proper order)	1-3
15.	Not complying with a lawful order	1-5
16.	Quibbling	1
17.	Violation of the Cadet Code of Conduct	5-10
18.	Threatening/aggressive behavior (toward other cadets)	5
19.	Public display of affection while in uniform	1-5

CHAPTER 24

Disciplinary Action

1. Disciplinary Action is reviewed and approved in the same manner as demerits are. Completed forms will be given to the Squadron Commander, then Deputy Group Commander for review and then to the SASI or ASI for final review. The top half of the form will go to the recipient and the bottom half will go to the Deputy Group Commander for tracking purposes. The function of Disciplinary Action is for cadets to learn (correct inappropriate conduct and/or behavior) and not receive remedial training again.
2. Disciplinary Action may be assigned by:
 - SASI or ASI
 - Group Commander or Deputy Group Commander
 - Squadron Commanders
 - Flight Commanders
 - Team Commanders
3. Disciplinary Action Appeals: If a cadet feels that he/she has been given remedial training unfairly, that there were extenuating circumstances, or that the amount given is excessive, he/she can appeal it. Write the reason(s) or circumstances for the appeal on the bottom of the Disciplinary Action form and submit it to the Group Commander. The Group Commander will make a decision based on all the possible information surrounding the disciplinary action.
4. Record Keeping: The Deputy Group Commander will ensure the SASI or ASI approves all Disciplinary Action before recording it to cadet records. The Deputy Commander will maintain records of all Disciplinary Action. A list of all cadets with Disciplinary Action will be posted every two weeks, along with a time and date on which the Disciplinary Action is to be performed.

CHAPTER 25

Outstanding Flight Competition

Selection for each semester Outstanding Flight will be based on the following scoring system.

Highest Inspection Percentage:	150 points - 1st Place 130 points - 2nd Place 110 points - 3rd Place 50 points - 4th Place 40 points - 5th Place 30 points - 6th Place
Greenery Sales (Fall Only):	200 points - 1st Place 150 points - 2nd Place 100 points - 3rd Place 75 points - 4th Place 50 points - 5th Place 25 points - 6th Place
Popcorn Sales :	200 points - 1st Place 150 points - 2nd Place 100 points - 3rd Place 75 points - 4th Place 50 points - 5th Place 25 points - 6th Place
Penny War (Spring Only):	150 points - 1st Place 125 points - 2nd Place 100 points - 3rd Place 75 points – 4 th Place 50 points – 5 th Place 25 points – 6 th Place
Team Attendance:	5 points per each cadet on team that attends -5 points per unexcused absence
Service Projects:	5 points per cadet per event -10 points per unexcused absence

“OTHER”:

- 5 points per cadet participating in CIA trip(s)
- 5 points per cadet paying dues by deadline
- 10 points per each cadet not paying dues by deadline/payment plan
- 5 points for each cadet passing all classes at end of grading cycle
- 10 points for flight having highest academic average per semester
- 10 points for each cadet recruited into JROTC before 10 Oct
- 10 points for flight having highest percentage attend military ball
- 5 points per cadet improving on PFT (-10 for any decrease)
- 10 points for flight winning Interflight Drill Competition
- 5 points for any cadet receiving “0” uniform discrepancies
- 5 points for any cadet whose shoes/boots shine as good as or better than Maj Sandlin’s

CADET STAFF JOB DESCRIPTIONS

- a. The **Cadet Group Inspector General** is responsible for:
- (1) Conducts annual Unit Self-Assessment.
 - (2) Prepares unit for tri-annual HQ inspection. Also POC for the visit.
 - (3) Standardizes unit procedures among the various flights and organizations.
 - (4) Evaluates performance of personnel and programs to ensure compliance with applicable regulations.
 - (5) Interprets intent of Handbook and other regulations where there is unclearness or contradictions.
 - (6) POC for Handbook issuance and production.
 - (7) Investigates complaints against leadership and reports findings to the CG/CC. If the CG/CC is investigated, report will be made to the SASI/ASI.
 - (8) Ensures CG/CC is informed of all activities related to his/her position.
 - (9) Perform tasks assigned by TX-861CG CC/CV, SASI and ASI.
- b. The **Group Commander** is responsible for:
- (1) The corps group commander will meet with the SASI by Tuesday of each week in order to coordinate corps activities. The corps commander will then prepare an agenda for the weekly staff meeting by Wednesday and will discuss it with the SASI.
 - (2) Holding weekly staff meetings to plan, organize, coordinate, control, and direct the cadet group activities. Give SASI the meeting agenda.
 - (3) The appearance, discipline, efficiency, training, and conduct of the group, and the accomplishment of the Leadership Training Program and mission as outlined by the SASI.
 - (4) Ensuring all members of the cadet corps have the opportunity to develop leadership commensurate with their individual abilities.
 - (5) Administering cadet corps activities according to Westwood High School and Air Force JROTC principles and procedures to achieve the corps goals.
 - (6) Establishing Primary/Alternate Project Officers for large corps events each semester. Monitoring the progress of the corps project officers and accomplishments of their project. Projects include but are not limited to:
 - Fall** – Fall CIA Trip, MS Walk, Homecoming, Tap-In, Prop and Wings, Veteran’s Day Parade, Holiday in the park.
 - Spring** – Change Of Command, Military Ball, McNeil Competition, MS-150, Interflight Competition, Spring CIA Trip, Annual Awards Banquet.
 - (7) Evaluates cadet appeals and complaints fairly and impartially.
 - (8) Ensure SASI/ASI are informed of all activities related to his/her position.

- c. The **Deputy Group Commander** is responsible for:
 - (1) Command of the group during the absence of the group commander.
 - (2) Monitoring corps suspense for the Group Commander and visually posting these in staff room and classroom.
 - (3) Supervising the group first sergeant, squadron commanders, and group guidon bearer.
 - (4) Assisting the group commander in the accomplishment of corps activities.
 - (5) Monitoring the neatness of the cadet staff room.
 - (6) Sign off on merit/demerit.
 - (7) Ensure Group CC is informed of all activities related to his/her position.

- d. The **Command Chief** is responsible for:
 - (1) Assisting the group commander in attaining and maintaining the highest standards of discipline, appearance, and morale of the corps.
 - (2) Scheduling flag detail at Westwood High School and maintaining detailed records of flag-detail activities.
 - (3) Holding periodic meetings with the cadet airmen for purposes of increasing morale, coordination, and rapport between cadets.
 - (4) Overseeing and mentoring all squadron first sergeants within the group.
 - (5) Scheduling popcorn detail at Westwood High School and maintaining detailed records of popcorn activities.
 - (6) Ensure Group CC/CV are informed of all activities related to his/her position.
 - (7) Perform duties as Group Guidon Bearer

- e. The **Safety Officer** is responsible for:
 - (1) Ensuring a daily/weekly weather report is posted in classroom and cadet office.
 - (2) Posting a pre-activity safety report for all outside activities.
 - (3) Coordinating with the PAO for articles in each cadet publication.
 - (4) Ensuring all supplies in First Aid Kit are fully stocked
 - (5) Ensuring all cadets are reminded of hydration needs prior to any AFJROTC event
 - (6) Coordinating with Logistics and the Booster Club to ensure there is an adequate supply of cups and water, to include proper maintenance, cleaning and pre-staging of coolers as needed at outdoor or indoor events.

- f. The **Group Health and Wellness Officer** is responsible for:
- (1) Trains, directs, mentors and evaluates assigned Flight H&W leaders.
 - (2) Coordinates with Flight H&W to ensure Health and Wellness program is executed IAW command staff guidance.
 - (3) Develops Health and Wellness program in line with AFJROTC directives
 - (4) Ensures group completion of Presidential Fitness Test within 45 days of the start of the school year.
 - (5) Ensures completion of second Presidential Fitness Test before school end.
 - (6) Maintains WINGS database, to include receipt of parental HW waiver and PT results.
 - (7) Plans, coordinates and executes corps field days/RRISD ROTC competitions to the greatest extent possible.
 - (8) Plans, coordinates and supervises corps for interscholastic field days as appropriate.
 - (9) Ensures CG/CC is informed of all activities related to his/her position.
- g. The **Operations Squadron Commander** is responsible for:
- (1) Planning and coordinating extracurricular and co-curricular activities that are not assigned to a special project officer.
 - (2) Assisting the SASI in scheduling base visits and similar activities.
 - (3) Assuming command of the group in the absence of the CC/CV.
 - (4) Supervising the operations teams
 - (5) Maintaining the corps calendar, staff room planning activity scheduling board, and classroom corps activity board.
 - (6) The Operations Squadron Commander will meet weekly with the ASI and commanders to coordinate team activities and uniform requirements.
 - (7) Give ASI a meeting plan for Operation meeting and weekly teams Maps.
 - (8) Ensure Group CC/CV are informed of all activities related to his/her position.
- h. The **Drill Team and Color Guard Commanders** are responsible for:
- (1) Training and supervising their respective teams.
 - (2) Scheduling, planning for, and participating in school and community events to the greatest extent possible.
 - (3) Establishing and maintaining written team policies and guidance (standard operating procedures) and providing a copy to SASI/ASI and place copy in continuity training folder in staff room.
 - (4) Coordinating with the Operations Squadron Commander on all team activities.
 - (5) Maintaining accurate records of each team member's practices, performances, service hours, and merit points. Also, maintaining equipment records, and notifying ASI of equipment repairs or supplies needed.
 - (6) Weekly, writing team merits and providing to Operations Squadron Commander.

- i. The **Rocketry/Model Airplane Commander** is responsible for:
 - (1) Managing, training, and supervising members of the rocketry team.
 - (2) Being knowledgeable of the guidance and directives for the AFJROTC model rocketry program.
 - (3) Establishing and maintaining written standard operating procedures for the team.
 - (4) Conducting an introduction to model rocketry course once each semester.
 - (5) Keeping records of members' launches, attendance at meetings, launches of each member of team.
 - (6) Enforcing standards in construction, launching, evaluation, and safety in the model rocketry program.
 - (7) Coordinating with the Operations Squadron Commander on all activities.
 - (8) Provide weekly merits and demerits to Operations Squadron Commander.
 - (9) Ensuring that part of the team meetings are directed to construction of model airplanes (Plastic, foam and wood to include gas and electric Remote Control/UAV models).
 - (10) Produce a rocket launch plan and aircraft flying plan (if applicable) each semester.

- j. The **Recruiting and Awareness Presentation Team Officer** is responsible for:
 - (1) Organizes trains and equips the RAPT Team.
 - (2) Ensures RAPT Team training is safe and effective
 - (3) Recruits new RAPT Team members.
 - (4) Supervises Public Service Academy JROTC ambassadors.
 - (5) Prepares RAPT Team for competitions and/or demonstrations.
 - (6) Safeguards RAPT Team equipment when in use. Ensures equipment is used properly and is not damaged through carelessness, abuse, or neglect. Ensures RAPT Team equipment is stored properly when not in use.
 - (7) Maintains accountability, submits attendance rosters and reports for all meetings, practices and events.
 - (8) Accomplishes other tasks as directed by the OS/CC.
 - (9) Ensures Operations Squadron Commander is informed of all activities related to his/her position.
 - (10) Ensuring plans are in place for conducting many events at Grisham and Canyon Vista Middle Schools each semester (presenting colors, chaperoning events, science fairs, etc., to also include the Civil War Reenactment at Spicewood Springs Elementary and Veterans Day presentation at Purple Sage Elementary)

- k. The **Mission Support Squadron Commander** is responsible for:
- (1) Ensuring that all assigned tasks and work within his/her squadron are completed on time and efficiently.
 - (2) Providing support to the other squadrons when needed through the use of subordinates (orders, logistical support, etc.).
 - (3) Holding a meeting at the MSS Commander's discretion based on the amount of work that MSS has to do and the urgency of communication within the squadron.
 - (4) Trains, directs, mentors and evaluates mission support personnel.
 - (5) Organizes, trains and equips squadron to accomplish its mission.
 - (6) Ensures subordinates maintain WINGS data, as appropriate
 - (7) Will meet weekly with the ASI to coordinate any uniform requirements, WINGS updates equipment maintenance and/or replacement needs as necessary.
 - (8) Plans New Student Orientation at the end of the Spring Semester for the upcoming year. Ensures Staff UMD is developed, Location and Dates are secured and activities are planned/coordinated with Booster Club as appropriate.
 - (8) Ensure Group CC/CV are informed of all activities related to his/her position.
- l. The **Information Management Officer** is responsible for:
- (1) Preparing, publishing, and distributing special orders and maintaining a master file of all special orders, and well as maintaining administration publications for or by the group. This includes the special orders, policies, procedures, and other letters. Also, maintain a copy of all project officer paper files and reports.
 - (2) Writing and posting orders as directed by the MSS Commander.
 - (3) Maintaining the cadet group files and forms in the staff room for ready access by cadets.
 - (4) Maintaining the log of control numbers to be assigned to special orders during the year.
 - (5) Preparing, publishing, distributing, and posting minutes of the group staff meetings by the following Mondays. Also, maintaining a master file of staff meeting minutes.
 - (6) Preparing a group Recall Roster by the second week of each semester which includes telephone and email contact information.
 - (7) Ensuring TX-861st Web page is developed and current each semester on Westwood Homepage.

m. The **Personnel Officer** is responsible for:

- (1) Maintaining a personnel record for each cadet in the JUMS and an up-to-date hard copy in the instructors' office file cabinet.
- (2) Updating cadet personnel records to ensure records are current, accurate, and standardized within the corps.
- (3) Maintaining attendance records for staff meeting and any corps training activity where attendance records are required.
- (4) Maintaining the corps organizational chart in the classroom.
- (5) Updating cadet service records in the computer database and maintaining up-to-date and accurate records of cadet service hours (JUMS and WINGS).
- (6) Preparing all promotion board packages and coordination.
- (7) Ensures Tutoring List is provided and signup sheets are ready within first two weeks of each semester.

n. The **Awards and Decorations** officer is responsible for:

- (1) Using the personnel JUMS system and corps service hour tracking program to determine what cadets have earned a ribbon and should be awarded any ribbons.
- (2) Accepting inputs from the flight commanders on recommendations for cadets deserving awards such as the cadet of the month, local awards, or JROTC ribbons.
- (3) Using JUMS coordinate ribbons earned with Information Management for Special Orders, and with the ASI for presentation of the awards. Notify Public Affairs of awards earned for newspaper and web pages.
- (4) Ensure WINGS is updated with cadet award data in coordination with Personnel Officer.
- (5) Other awards activities as assigned by the ASI or the awards banquet project officer.
- (6) Maintaining records of the merit/demerit program on the staff computer and posting biweekly in classroom.

o. The **Logistics Officer** is responsible for:

- (1) Assisting the ASI in the issue and turn-in of all government accounted property.
- (2) Assisting the ASI in the periodic inventory of accounted property in WINGS.
- (3) Ensuring that the logistics room is manned from 0800-0900 and 1630-1730 Monday through Thursday.
- (4) Reminding cadets and flight commanders of cadets who have borrowed items that are overdue after three days of borrowed use.
- (5) Periodically inspecting the condition of uniforms and equipment for serviceability and coordinate repair of equipment needing repair.
- (6) Making sure that every item in the logistics room is inventoried and accounted for.

p. The **Public Affairs Officer** is responsible for:

- (1) Maintaining cadet corps public relations at the highest possible level.
- (2) Providing newsworthy items about the corps, the cadets, and their activities to school and local newspapers, radio stations, TV stations and other news media by submitting an article to the school newsletter every month and if need be, to local news publications.
- (3) Providing the cadet corps input to the Westwood High School yearbook staff.
- (4) Coordinate the actions of all Public Affairs NCOs in video, newspaper, web pages, and historian still photos.
- (5) Publishing a group newsletter or newspaper each six weeks using inputs from all the cadet staff.
- (6) Taking photos of all corps activities by using NCOs and other corps members and corps cameras and getting corps photos developed for news stories, yearbook, and scrapbook.
- (7) Managing corps still 35mm and video camera equipment and supplies.
- (8) Making and keeping a log by date of all events accomplished by the corps for annual inspection and history book. Developing and managing unit historical book with names and photos, history or journal activity listing of all corps events for year and other records that reflect the activities and tradition of the TX-861 cadet corps.
- (9) Maintaining (keep them updated) the corps bulletin boards/trophy cases:
 1. In school by library/atrium
 2. Two in ROTC Building hallways
 3. ROTC classroom

q. The **Finance Officer** is responsible for:

- (1) Reporting to SASI and receiving orders for organization of cadet corps finances. All actual money transfers and business will only be conducted by either the ASI or SASI.
- (2) Managing penny wars and producing an accurate Group budget for the Booster Club within the first two weeks of each semester.
- (3) Plans, organizes and executes fundraising activities for the financing of corps activities.

- r. The **Electronic Systems (Comms) Officer** is responsible for:
- (1) Maintaining cadet computers/printers, resolving software error messages, and reloading authorized software/ink if needed.
 - (2) Assisting cadets on staff in setting up cadet programs, forms, and software programs on computers. Developing computer forms and spreadsheets to make staff function efficient.
 - (3) Inventorying all electronic hardware and software within the corps and any other function as directed by the Group Commander or SASI for WINGS accountability.
 - (4) Ensuring CPS, clickers and MOBI systems are functioning properly.
 - (5) Ensuring printers have adequate ink and paper supplies.
- s. The **Squadron Commanders** are responsible for:
- (1) Monitoring merits and demerits in their squadron.
 - (2) Collecting/tracking all points for Outstanding Flight competition and reporting to Awards and Decs Officer for final tally.
 - (3) Performing drill and ceremonies each promotion cycle and corps parades as assigned.
 - (4) Ensuring cadets follow the cadet guide rules.
 - (5) Monitoring uniform wear and conduct/behavior in their squadron.
 - (6) Planning squadron competitions and fun activities for their squadron.
- t. The **Flight Commanders** are responsible for:
- (1) The discipline, training, and conduct of his/her flight when together as a flight.
 - (2) Ensuring a high proficiency in the basic fundamentals of drill and ceremonies, customs and courtesies, and uniform appearance.
 - (3) Scheduling cadets so that each cadet has the opportunity to develop his/her leadership traits commensurate with the cadet's abilities.
 - (4) Accurately accounting for and reporting attendance each school day and reporting all scheduled events and activities to his/her flight.
 - (5) Involving all cadets of his/her flight in group activities.
 - (6) Originating constructive service projects once a month, fund raising, and other projects for their flight.
 - (7) Presenting nomination packages/letters for special awards/promotions as required.
 - (8) Maintaining effective communications throughout their flight and chain of command.

- u. The **Flight Sergeants** are responsible for:
 - (1) Following the directives of and assisting the his/her flight commander in fulfilling his/her duties.
 - (2) Representing the flight commander in his/her absence.
 - (3) Calling the flight to attention at the bell, taking the absence report, and reporting to the Flight Commander.

- v. The **Element Leader** is responsible for:
 - (1) The actions and conduct of his/her element.
 - (2) Providing leadership training by example.
 - (3) Reporting attendance in his/her element.

- w. The **Flight Guide** is responsible for:
 - (1) Carrying out responsibilities as outlined in 36-2203 and the Drill and Ceremonies Guide. In addition, the primary and alternate Guidon bearer will attend Guidon practice once a week as proscribed by the SASI.

TX-861 Unit Manning Document

FUNCTION	POSITION TITLE	MAX RANK	AUTHORIZED
Command Group	Commander (CC)	Cadet Col.	1
	Deputy Group (CV)	Cadet Lt. Col.	1
	Command Chief	Cadet CMSgt	1
	Inspector General (IG)	Cadet Col.	1
Squadron	Squadron (SQ) CC	Cadet Maj.	2
	First Sergeant	Cadet SMSgt	2
	Flight CC	Cadet Col.	6
	Flight Sergeant	Cadet SMSgt	6
	Flight Guidon	Cadet SMSgt	6
Operations	Ops SQ/CC	Cadet Maj.	1
	First Sergeant	Cadet SMSgt	1
	Drill Team CC	Cadet Capt.	1
	Color Guard CC	Cadet Capt.	1
	Rocketry CC	Cadet Capt.	1
	Guidon CC	Cadet Capt.	1
	Health and Wellness Officer	Cadet Capt.	1
	Recruiting/Retention Officer	Cadet Capt.	1
	NCOs	Cadet TSgt	5
Mission Support	MSS CC	Cadet Maj.	1
	First Sergeant	Cadet SMSgt.	1
	Awards and Decs Officer	Cadet Capt.	1
	Personnel Officer	Cadet Capt.	1
	Finance Officer	Cadet Capt.	1
	Information Mgt Officer	Cadet Capt.	1
	Public Affairs Officer	Cadet Capt.	1
	Logistics Officer	Cadet Capt.	1
	Electronic Syst. Officer	Cadet Capt.	1
	Safety Officer	Cadet Capt.	1
	NCOs	Cadet TSgt	11

TX - 861 Promotion Checklist used in the "Whole Person" Concept

Cadet Name: _____ Date: _____ Current Rank _____

Fill out and get instructor/cadet staff officer (as designated) to initial/verify promotion points. All staff NCOs must have a promotion recommendation from your staff officer. Each cadet must have your C/flight commander's promotion recommendation. C/flight commander will collect and provide to C/squadron commander for his/her recommendation. C/squadron commander will forward all promotion forms to C/deputy group commander. Upon receipt, C/CC or CV will make promotion recommendation for all staff officers. SASI or ASI reviews, and if promotion is approved, provides to Information Management to publish promotion orders.

Verify Eligibility for Promotion	Initial By	Initials - Yes /No
Logistics Items Cleared	C/Logistics	_____
Financial Obligations Cleared	C/Finance	_____
Passing Grades in AFJROTC	SASI/ASI	_____
Passing Grades in all Academic Classes	SASI/ASI	_____
Clear of Disciplinary Action	SASI	_____
Team Commander (participation of team)	C/Tm Cmdr	_____
Service Hours (15)	C/Personnel	_____
Immediate Commanding Officers' approval	C/OIC	_____
Flight Commander's approval	C/Flt Cmdr	_____
Squadron Commander's approval	C/Sqrn Cmdr	_____
Deputy Group Commander's approval	C/D Grp	_____
Group Commander's approval	C/Grp	_____
Aerospace Science Instructor's approval	ASI	_____
Senior Aerospace Science Instructor's approval	SASI	_____
Completion of SLS (may be waived at SASI discretion)	SASI	_____
Passing of JROTC Skills Knowledge Test (SKT)	C/Personnel	_____
Board Interview Including Uniform Inspection	C/Gp CC/CV	_____

Military Letter Format

DEPARTMENT OF THE AIR FORCE

AIR FORCE JUNIOR RESERVE OFFICER TRAINING CORPS

TEXAS 861ST CADET GROUP

DATE: _____

MEMORANDUM FOR: _____

MEMORANDUM FROM: _____

SUBJECT: _____

(Cadet Rank and Signature)

AFJROTC Awards and Decorations







AIR FORCE JUNIOR ROTC

Wear Your Ribbons Proudly & Properly











1  Air Force JROTC Valor Award (Gold)	2  Air Force JROTC Valor Award (Silver)	3  Cadet Humanitarian Award	4  Community Service with Excellence Award	5  Air Force Association Award
6  Daedalian Award	7  American Legion Scholastic Award	8  American Legion General Military Excellence Award	9  Daughters of the American Revolution Award	10  American Veterans Award
11  Reserve Officers Association Award	12  The Military Order of World Wars Medal	13  Military Officers Association Award	14  Veterans of Foreign Wars Award	15  National Sojourners Award
16  Sons of the American Revolution Award	17  Scottish Rite, Southern Jurisdiction Award	18  Military Order of the Purple Heart	19  Air Force Sergeant Association	20  Sons of Union Veterans of the Civil War
21  Sons of Confederate Hunley Award	22  Tuskegee Airmen Inc. AFJROTC Cadet Award	23  The Retired Enlisted Association Award	24  Celebrate Freedom Foundation/ Embry Riddle Aeronautical University JROTC Award	25  National Society United States Daughter of 1812
26  ACA Medal	27  Non Funded National Award	28  Distinguished Unit Award	29  Outstanding Organization Award	30  Outstanding Flight Ribbon
31  Top Performer Award	32  The Outstanding Cadet Ribbon	33  Leadership School Ribbon	34  Achievement Ribbon	35  Superior Performance Ribbon
36  Academic Ribbon	37  Leadership Ribbon	38  Special Teams Competition	39  Orienteering Ribbon	40  Cocurricular Activities Leadership Ribbon
41  Drill Team Ribbon	42  Color Guard Ribbon	43  Sabre Team Ribbon	44  Marksmanship Ribbon	45  Good Conduct Ribbon
46  Service Ribbon	47  Health and Wellness	48  Recruiting Ribbon	49  Activities Ribbon	50  Attendance Ribbon
51  Dress & Appearance Ribbon	52  Longevity Ribbon	53  Gen Carl Spaatz Award (CAP)	54  Gen Ira C. Eaker Award (CAP)	55  Amelia Earhart Award (CAP)
	56  Gen Billy Mitchell Award (CAP)	57  Gen J.F. Curry Achievement Award (CAP)		







SPECIAL AWARDS







AWARD	CADET REQUIREMENTS:	ELEMENT(S)
(Eligibility)		
<i>Valor Award (Gold)</i> (All Cadets)	Recognizes the most outstanding voluntary acts of self-sacrifice and personal bravery by a cadet involving conspicuous risk of life above and beyond the call of duty.	Medal, Ribbon, Certificate 
<i>Valor Award (Silver)</i> (All Cadets)	Awarded to a cadet for a voluntary act of heroism which does not meet the risk-of-life requirements of the Gold Valor Award.	Medal, Ribbon, Certificate 
<i>Cadet Humanitarian Award</i> (All Cadets)	It is intended to recognize cadets who provide aid in response to a singular extraordinary event such as a natural disaster or other catastrophe that has placed or has the potential to place a hardship on their fellow citizens. This award is not to be used to recognize day-to-day service in the community.	Ribbon, Certificate 
<i>Community Service with Excellence Award</i> (All Cadets)	Recognizes those individual cadets who provide significant leadership in the planning, organizing, directing, and executing of a major unit community service project that greatly benefit the local community. This is not an award given to participants but to the key leader(s) of the project.	Ribbon, Certificate 

NATIONAL AWARDS





AWARD	CADET REQUIREMENTS	ELEMENT(S)
(Eligibility)		
<i>Air Force Association Award (AS-III)</i>	<ul style="list-style-type: none"> -Positive attitude (toward AFJROTC and school). -Outstanding personal appearance (uniform and grooming). -Display personal attributes such as initiative, judgment, and self-confidence. -Courteous demeanor (promptness, obedience, and respect for customs). 	Medal, Ribbon 
<i>Daedalian Award (AS-III,IV)</i>	<ul style="list-style-type: none"> -Demonstrate an understanding and appreciation of patriotism, love of country, and service to the nation. -Indicate the potential and desire to pursue a military career. -Rank in the top 10% of their AS class. -Rank in the top 20% of their school class. 	Medal, Ribbon 









<p><i>American Legion Scholastic Award</i> (AS-III or IV)</p>	<ul style="list-style-type: none"> -Rank in the top 10% of the high school class. -Rank in the top 25% of their AS class. -Demonstrate leadership qualities. -Actively participate in student activities 	<p>Medal, Ribbon</p> 
<p><i>American Legion General Military Excellence Award</i> (AS-III or IV)</p>	<ul style="list-style-type: none"> -Rank in the top 25% of their AFJROTC class. -Demonstrate outstanding qualities in military leadership, discipline, character, and citizenship. 	<p>Medal, Ribbon</p> 
<p><i>Daughters of the American Revolution Award</i> (AS-IV)</p>	<ul style="list-style-type: none"> -Rank in the top 25% of their AS class. -Rank in the top 25% of their high school class. -Demonstrate qualities of dependability and good character. -Demonstrate adherence to military discipline. -Possess leadership ability and a fundamental and patriotic understanding of the importance of JROTC training. 	<p>Medal, Ribbon</p> 
<p><i>American Veterans Award</i> (All Cadets)</p>	<ul style="list-style-type: none"> -A positive attitude toward AFJROTC programs and service in the Air Force. -Personal appearance (wearing of the uniform, posture, and grooming, but not physical characteristics per se). -Personal attributes (initiative, dependability, judgment, and self-confidence). -Officer potential (capacity for responsibility, adaptability, and maintenance of high personal standards). -Obtained a grade of "A" in their AS class. -Be in good scholastic standing in all classes at the time of selection and at the time of presentation. 	<p>Medal, Ribbon</p> 
<p><i>Reserve Officers Association Award</i> (AS-IV)</p>	<ul style="list-style-type: none"> -Positive attitude toward the AS curriculum. -Outstanding personal appearance (wear of the uniform, posture, and grooming). -Attributes of initiative, judgment, and self-confidence. -Courtesy (promptness, obedience, and respect). -Growth potential (capacity for responsibility, high productivity, adaptability to change). -Demonstrate the highest personal, ethical standards & strong positive convictions. -Rank in the top 10% of their AS class. 	<p>Ribbon, Certificate</p> 
<p><i>Military Order of World Wars Award</i> (AS-I, II, III)</p>	<ul style="list-style-type: none"> -Committed to continue the aerospace science program the following school year. -Outstanding accomplishments or service to the AFJROTC unit. 	<p>Medal, Ribbon, Certificate</p> 





<p><i>Military Officers Association Award</i> (AS-III)</p>	<ul style="list-style-type: none"> -Be a member of the junior class. -Be in good academic standing. -Be of high moral character. -Show a high order of loyalty to the unit, school, and country. -Show exceptional potential for military leadership. 	<p>Medal, Ribbon</p> 
<p><i>Veterans of Foreign Wars Award</i> (AS-III or IV)</p>	<ul style="list-style-type: none"> -Have a positive attitude toward AFJROTC. -Have outstanding military bearing and conduct. -Possess strong positive personal attributes (such as courtesy, dependability, punctuality, respect, and cooperation). -Demonstrate patriotism (being a member of the color guard or drill team) and actively promote Americanism. -Demonstrate leadership potential. -Attain a grade of "B" in AFJROTC with an overall average grade of "C" in all subjects for the previous semester. -Be active in student activities. -Not have been previous recipients of this award. 	<p>Medal, Ribbon</p> 
<p><i>National Sojourners Award</i> (AS-II or III)</p>	<ul style="list-style-type: none"> -Be in the top 25% of their academic class. -Encourage and demonstrate ideals of Americanism. -Demonstrate potential for outstanding leadership. -Not have previously received the award. 	<p>Medal, Ribbon, Certificate</p> 
<p><i>Sons of the American Revolution Award</i> (AS-III)</p>	<ul style="list-style-type: none"> -Exhibit a high degree of leadership, military bearing, and all-around excellence in AS studies -Not previously received the award. -Currently enrolled in the AFJROTC program. -Top 10% of their AFJROTC class. -Top 25% of their overall class. 	<p>Medal, Ribbon</p> 
<p><i>Scottish Rite, Southern Jurisdiction Award</i> (AS-III)</p>	<ul style="list-style-type: none"> -Participation in extracurricular activities or community projects. -Top 25% of class. -Qualities of dependability, good character, self-discipline, good citizenship and patriotism. -Has not been a previous recipient of this award. 	<p>Medal, Ribbon, Certificate</p> 
<p><i>Military Order of the Purple Heart Award</i> (AS-III or IV)</p>	<ul style="list-style-type: none"> -Have a positive attitude toward AFJROTC and country. -Hold a leadership position in the cadet corps. -Be active in school and community affairs. -Attain a grade of "B" or better in all subjects for the previous -semester. -Not have been a previous recipient of this award. 	<p>Medal, Ribbon, Certificate</p> 
<p><i>Air Force Sergeant Association Award</i> (AS-III or IV)</p>	<ul style="list-style-type: none"> -Be in the top 25% of the AFJROTC class. -Demonstrate outstanding qualities in military leadership, discipline, character, and citizenship. -Not have been a previous recipient of this award. 	<p>Medal, Ribbon</p> 

<p><i>Sons of Union Veterans of the Civil War Award</i> (AS I, II, III, or IV)</p>	<p>-Demonstrated high degree of patriotism and have -Demonstrated a high degree of academic excellence - Leadership ability.</p>	<p>Medal, Ribbon </p>
<p><i>Sons of Confederate Veterans Hunley Award</i> (AS-I)</p>	<p>Demonstrate the qualities of Honor, Courage and in particular Commitment to his/her unit throughout the school year.</p>	<p>Medal, Ribbon, Certificate </p>
<p><i>Tuskegee Airmen Incorporated AFJROTC Cadet Award</i> (AS-I, II, III) 2 cadets</p>	<p>-Attain a grade of “B” or better in their AS class. -Be in good academic standing. -Actively participate in cadet corps activities. -Participate in at least 50% of all unit service programs.</p>	<p>Ribbon, Certificate </p>
<p><i>The Retired Enlisted Association Award</i> (Any Enlisted Cadets)</p>	<p>Outstanding leadership throughout the course of the school year.</p>	<p>Medal, Ribbon, Certificate </p>
<p><i>The Celebrate Freedom Foundation Award</i> (AS-I, II)</p>	<p>Outstanding performance in academics and cadets corps activities.</p>	<p>Ribbon, Certificate </p>
<p><i>National Society Daughters of 1812 Award</i></p>	<p>Awarded annually, at the SASI’s discretion, for academic excellence, leadership, military discipline, dependability, patriotism and upright character in speech and habits. This award consists of a ribbon, medal and certificate.</p>	<p>Medal, Ribbon, Certificate </p>
<p><i>Air Commando Association Award</i></p>	<p>Complete a one page essay based on a historical AF Special Operations Mission possessing the thirteen critical attributes of success: integrity, self-motivation, intelligence, self-discipline, perseverance, adaptability, maturity, judgment, selflessness, leadership, skilled, physical fitness and family strength.</p>	<p>Medal, Ribbon, Certificate </p>
<p>Note 1. When the requirements for an award state that it should be given to an AS-III, the intent is that the award be given to a cadet who has one year remaining in AFJROTC. All rising seniors will be eligible for AS-III awards.</p>		
<p>Note 2. If no cadet meets all the requirements for a given award, the SASI has the authority to award it to the most deserving cadet.</p>		

AFJROTC AWARDS

AWARD	CADET REQUIREMENT:	ELEMENT(S)
(Eligibility)	(Frequency)	
<i>Distinguished Unit Award</i> (All Cadets)	<ul style="list-style-type: none"> -Unit (TX-861) <u>Not on Probation</u> -Has had a rated unit evaluation -Met standards on most recent evaluation -Met all required suspense's -SASI concurs with unit award evaluation -("with merit" during inspection year for "Exceeds Standards") -Average 12 hours of community service hours per cadet. (Annual-2 nd Semester)	Ribbon  (+ Silver Star for "with merit")
<i>Outstanding Organization Award</i> (All Cadets)	Same as above except: <ul style="list-style-type: none"> -No "with merit possible" -Average 8 hours community service hours per cadet. (Annual-2 nd Semester)	Ribbon 
<i>Outstanding Flight Ribbon</i> (All Cadets)	Awarded each academic term to members of the outstanding flight under criteria determined by the SASI. (Each Semester)	Ribbon 
<i>Top Performer Award</i> (All Cadets)	Top 2% of cadets. <ul style="list-style-type: none"> -Consideration given to those not previously recognized -Leadership and Job Performance in key areas: <ul style="list-style-type: none"> --Primary Duty, especially in preparing for annual assessment --Involvement and positions held in extracurricular activities --Good academic standing in all courses --Significant self-improvement --Community involvement -During Evaluation Year <ul style="list-style-type: none"> --Presented by Regional Director -During Non-Evaluation Years <ul style="list-style-type: none"> --SASI may select recipients and present the award (Annual-2 nd Semester)	Certificate, Ribbon 
<i>The Outstanding Cadet Ribbon</i> (One Cadet each AS I- IV)	<ul style="list-style-type: none"> -Have high moral character, -Demonstrate positive personal attributes -Display outstanding military potential, -Attain academic and military excellence. (Annual-2 nd Semester)	Ribbon 





<p><i>Leadership Ribbon</i> (All Cadets)</p>	<p>-Outstanding performance in a position of leadership as an AFJROTC cadet in corps training activities. -Consistently displayed outstanding leadership ability above and beyond expected performance. (Annual-2nd Semester)</p>	<p>Ribbon </p>
<p><i>Achievement Ribbon</i> (All Cadets) Limit 1/year</p>	<p>Awarded for a significant achievement as deemed appropriate by the SASI. (Each semester, as required)</p>	<p>Ribbon </p>
<p><i>Superior Performance Ribbon</i> (All Cadets)</p>	<p>Awarded annually at the SASI's discretion for outstanding achievement or meritorious service rendered specifically on behalf of AFJROTC. Present the ribbon for a single or sustained performance of a superior nature. Ensure award is presented in recognition of achievements and services which are clearly outstanding and exceptional when compared to achievements and accomplishments of other cadets. (Annual-2nd Semester)</p>	<p>Ribbon </p>
<p><i>Academic Ribbon</i> (All Cadets)</p>	<p>Awarded for academic excellence as signified by attaining an overall grade point average of at least "B" for one academic term, in addition to an "A" average in AFJROTC. (Each Semester)</p>	<p>Ribbon </p>
<p><i>Leadership School Ribbon</i> (All Cadets)</p>	<p>Awarded for completion of an approved leadership school program. Bronze star awarded for additional schools. Silver star will be awarded for Distinguished Graduates. (Annual-1st Semester)</p>	<p>Ribbon </p>
<p><i>Special Teams Competition</i> (All Cadets)</p>	<p>Awarded to team members for placing 1st, 2nd or 3rd in an Air Force or Joint Service Competition to include Color Guard Teams, Rifle Teams, Drill Teams, Saber Teams, Academic Bowl Teams, Cyber Patriot, etc. (Each Semester, as required)</p>	<p>Ribbon </p>
<p><i>Orienteering Ribbon</i> (All Cadets)</p>	<p>Awarded to team members for completing unit specific Orienteering Program as part of unit curriculum. (Each Semester, as required)</p>	<p>Ribbon </p>
<p><i>Cocurricular Activities Leadership Ribbon</i> (All Cadets) Limit 4/cadet</p>	<p>Awarded at the SASI's discretion for leadership in AFJROTC cocurricular activities (such as dining-in chairperson, military ball chairperson, etc.). The recipient must have demonstrated exceptional leadership in achieving objectives through the coordinated efforts of others. (Each Semester, as required)</p>	<p>Ribbon </p>
<p><i>Drill Team Ribbon</i> (All Cadets)</p>	<p>-Sign up for Special Team -Participate in 75% of practices -Compete in at least two Drill Performances (Annual-2nd Semester)</p>	<p>Ribbon </p>

<p><i>Color Guard Ribbon</i> (All Cadets)</p>	<p>-Sign up for Special Team -Participate in 75% of practices. Compete in at least five honor guard performances (Annual-2nd Semester)</p>	<p>Ribbon </p>
<p><i>Saber Team Ribbon</i> (All Cadets)</p>	<p>-Sign up for Special Team -Participate in 75% of practices. Compete in at least two performances (Annual-2nd Semester)</p>	<p>Ribbon </p>
<p><i>Marksmanship Ribbon</i> (All Cadets)</p>	<p>Participate in program, qualified by civilian marksmanship program (Annual-2nd Semester)</p>	<p>Ribbon </p>
<p><i>Good Conduct Ribbon</i> (All Cadets)</p>	<p>No expulsions, suspensions, referrals, Letters of Reprimand, Letters of Counseling, or adverse reports from any teacher or member of the administration. (Each Semester, as required)</p>	<p>Ribbon </p>
<p><i>Service Ribbon</i> (All Cadets)</p>	<p>Distinctive performance in a minimum of 18 hours in three or more for any activity in AFJROTC-sponsored community service hours are awarded. An additional oak leaf cluster will be awarded for 36 community service hours in one academic year. --Scoring period begins day after previous year's Spring Awards Ceremony and ends the day prior to the current year's ceremony. (Each Semester, as required)</p>	<p>Ribbon </p>
<p><i>Health & Wellness</i> (All Cadets)</p>	<p>-Must make an "A" in Health and Wellness during enrollment period. -Must complete President's Physical Fitness Test Additional Awards -Score in the 75-84 percentile (additional Ribbon + bronze star) -Score in the 85-95 percentile (additional Ribbon + silver star) -Score in the 96-100 percentile (additional Ribbon + gold star) (Each Semester, as required)</p>	<p>Ribbon </p>





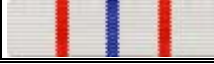

<p><i>Recruiting Ribbon</i> (All Cadets)</p>	<p>-Enroll at least one new 9th or 10th grade cadet. -Must be enrolled prior to October and remain for entire semester. -Recruiter must “claim” new cadet prior to showing up on roster. (Annual-1nd Semester) -or- -Sign up for RAPT Special Team -Participate in 80% of practices/events. -Participate in at least 2 Middle School Visits (Annual-2nd Semester)</p>	<p>Ribbon</p> 
<p><i>Activities Ribbon</i> (All Cadets)</p>	<p>Membership on any <u>One</u> team qualifies for the award: -Must have participated in 75% of meetings. <u>Four</u> of the following items qualifies for the award: -One CIA Field Trip -One Military Ball -One Awards Ceremony -One New Cadet Orientation (Instructor or Attend) -One Hal Aaron Drill Meet at McNeil -One Fundraising Event participation (Popcorn/Greenery) (Annual-2nd Semester)</p>	<p>Ribbon</p> 
<p><i>Attendance Ribbon</i> (All Cadets)</p>	<p>-Must be enrolled entire semester. -No unexcused absences -No more than 8 excused absences in all classes -Two tardies equals one excused absence. (Each Semester, as required)</p>	<p>Ribbon</p> 
<p><i>Dress and Appearance Ribbon</i> (All Cadets)</p>	<p>-No unexcused uniform inspections -No more than one late uniform --Incorrect UOD counts as missed uniform -Must have a minimum average score of 80% -Must have uniform issued for at least 8 inspections (Each Semester, as required)</p>	<p>Ribbon</p> 
<p><i>Longevity Ribbon</i> (All Cadets)</p>	<p>Received credit for two semester of JROTC</p>	<p>Ribbon</p> 



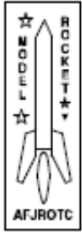

CIVIL AIR PATROL (CAP) AWARDS

Only five CAP ribbons (Gen. Spaatz Award, Amelia Earhart Award, Gen. Mitchell Award, Gen. Curry Achievement Award, and Gen. Eaker Award) may be worn on the AFJROTC uniform. Units should contact the nearest CAP unit to obtain awards, invite presenters, or obtain any guidance on criteria or presentation.

AWARD	CADET REQUIREMENT:	ELEMENT(S)
<i>General Carl Spaatz Award</i>	IAW CAP Requirements	Ribbon 
<i>General Ira C. Eaker Award</i>	IAW CAP Requirements	Ribbon 
<i>Amelia Earhart Award</i>	IAW CAP Requirements	Ribbon 
<i>General Billy Mitchell Award</i>	IAW CAP Requirements	Ribbon 
<i>General J. F. Curry Achievement Award</i>	IAW CAP Requirements.	Ribbon 

Air Force Junior ROTC Badges

BADGE	CADET REQUIREMENT:	DEVICE
<i>Officer's Flight Cap and Beret Insignia</i>	Commissioned as an officer in AFJROTC	
<i>Officer's Service Cap Insignia</i>	Commissioned as an officer in AFJROTC	
<i>Ground School Badge</i>	Awarded for successful completion of the AFJROTC aviation honors ground school curriculum or successful completion of another aviation ground school program prescribed by the FAA.	
<i>Flight Solo Badge</i>	Awarded to any cadet possessing a solo flight certificate signed by a FAA certified flight instructor for either powered or non-powered aircraft.	
<i>Pilot Certificate Badge</i>	Awarded to any cadet who possesses a valid FAA pilot's certificate for either powered or non-powered aircraft.	
<i>Model Rocketry Badge</i>	Awarded to cadets who have fulfilled model rocketry program requirements. Program requirements are listed in the Model Rocketry Handbook.	
<i>Awareness Presentation Team Badge</i>	Awarded for participation on an Awareness Presentation Team.	

<p><i>Distinguished AFJROTC Badge</i></p>	<p>This annual award recognizes one outstanding third-year cadet selected at the end of each school year. The recipient must be of high moral character, demonstrate positive personal attributes, display outstanding military potential, and maintain consistent academic and military excellence.</p>	
<p><i>Academy of Model Aeronautics Silver Wings</i></p>	<p>Awarded to cadets who are members of a local AMA chartered model airplane club.</p>	
<p><i>Kitty Hawk Air Society Badge</i></p>	<p>Awarded to cadets who are members of the Kitty Hawk Air Society. The Kitty Hawk charter should spell out the requirements for entry into the society.</p>	
<p><i>Aerospace Education Foundation (AEF) Academic Cadet Badge.</i></p>	<p>Awarded to rising Junior and Senior cadets for academic excellence as signified by attaining an overall 3.3 grade point average (on a 4.0 scale) with no grade below "C" on their transcript.</p>	
<p><i>Shoulder Tabs</i></p>	<p>Cadets are authorized to wear one shoulder tab on the right shoulder of the service dress coat, lightweight blue jacket and the light blue shirt. The SASI will designate which activities will be denoted by shoulder tabs and set the criteria for each.</p>	

AIR FORCE JUNIOR ROTC INSIGNIA

CADET OFFICER RANK



SECOND
LIEUTENANT



FIRST
LIEUTENANT



CAPTAIN



MAJOR



LIEUTENANT
COLONEL



COLONEL

CADET AIRMAN RANK

(no rank insignia)

AIRMAN BASIC

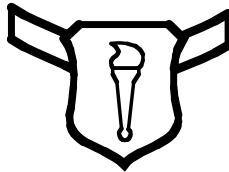

AIRMAN

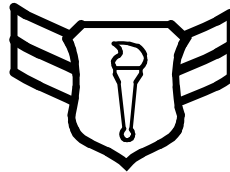

AIRMAN
FIRST CLASS

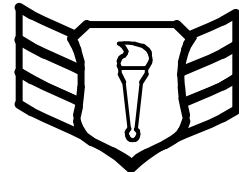

SENIOR
AIRMAN

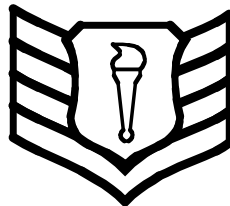

STAFF
SERGEANT



TECHNICAL
SERGEANT



MASTER
SERGEANT

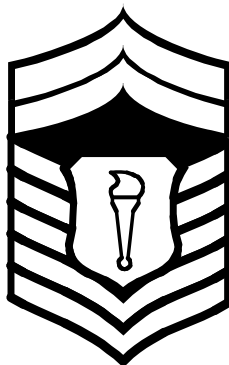

SENIOR
MASTER
SERGEANT

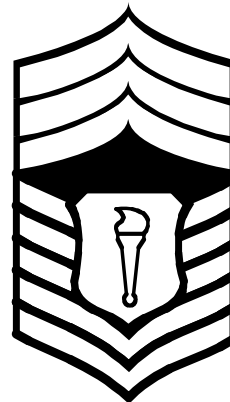

CHIEF
MASTER
SERGEANT

United States Air Force Grades and Insignia

Enlisted

Airman Basic, E-1, no insignia



Airman, E-2



Airman First Class, E-3



Senior Airman, E-4



Staff Sergeant, E-5



Technical Sergeant, E-6



*Diamond denotes First Sergeant status.

Master Sergeant, E-7



Senior Master Sergeant, E-8



Chief Master Sergeant, E-9



Command Chief Master Sergeant



Chief Master Sergeant of the Air Force

Officer



Second Lieutenant, O-1



First Lieutenant, O-2



Captain, O-3



Major, O-4



Lieutenant Colonel, O-5



Colonel, O-6



Brigadier General, O-7



Major General, O-8



Lieutenant General, O-9



General, O-10

Airman Promotion Board Score Sheet

(For Promotions to Cadet Senior Airman)

Cadet: _____ Job Title(s): _____

Current Rank: _____

PROMOTION ELEMENTS:

Job performance: SATISFACTORY / UNSATISFACTORY

Participation in JROTC Activities: SATISFACTORY / UNSATISFACTORY

Board Interview and Inspection: SATISFACTORY / UNSATISFACTORY

JROTC Skills/Knowledge Test: SATISFACTORY / UNSATISFACTORY

PROMOTION RECOMMENDATION:

INELIGIBLE

PROMOTE (Fully Qualified)

DO NOT PROMOTE (Not Fully Qualified)

Board President Signature: _____ Date: _____

Senior Instructor: APPROVED / DISAPPROVED

Senior Instructor Signature: _____ Date: _____

NCO Promotion Board Score Sheet

(For Promotions Staff and Technical Sergeants)

Cadet: _____ Job Title(s): _____

Current Rank: _____

PROMOTION ELEMENTS:

Job performance: 1 - 2 - 3 - 4 - 5 - 6 - 7 - 8 - 9 - 10

Participation in JROTC Social Activities: 1 - 2 - 3 - 4 - 5 - 6 - 7 - 8 - 9 - 10

Participation in JROTC Community Service: 1 - 2 - 3 - 4 - 5 - 6 - 7 - 8 - 9 - 10

Participation in Special Teams: 1 - 2 - 3 - 4 - 5 - 6 - 7 - 8 - 9 - 10

Board Interview and Inspection: 1 - 2 - 3 - 4 - 5 - 6 - 7 - 8 - 9 - 10

JROTC Skills/Knowledge Test: 1 - 2 - 3 - 4 - 5 - 6 - 7 - 8 - 9 - 10

PROMOTION RECOMMENDATION:

INELIGIBLE

PROMOTE IF BEST QUALIFIED SCORE: _____

DO NOT PROMOTE (Not Fully Qualified)

Board President Signature: _____ Date: _____

Senior Instructor: APPROVED / DISAPPROVED

Senior Instructor Signature: _____ Date: _____

SNCO Promotion Board Score Sheet

(For Promotions MSGT through CMSgt)

Cadet: _____ Job Title(s): _____

Current Rank: _____

PROMOTION ELEMENTS:

Job performance: 1 - 2 - 3 - 4 - 5 - 6 - 7 - 8 - 9 - 10

Participation in JROTC Social Activities: 1 - 2 - 3 - 4 - 5 - 6 - 7 - 8 - 9 - 10

Participation in JROTC Community Service: 1 - 2 - 3 - 4 - 5 - 6 - 7 - 8 - 9 - 10

Participation in Special Teams: 1 - 2 - 3 - 4 - 5 - 6 - 7 - 8 - 9 - 10

Board Interview and Inspection: 1 - 2 - 3 - 4 - 5 - 6 - 7 - 8 - 9 - 10

JROTC Skills/Knowledge Test: 1 - 2 - 3 - 4 - 5 - 6 - 7 - 8 - 9 - 10

PROMOTION RECOMMENDATION:

INELIGIBLE

PROMOTE IF BEST QUALIFIED SCORE: _____

DO NOT PROMOTE (Not Fully Qualified)

Board President Signature: _____ Date: _____

SASI Interview: SATISFACTORY/UNSATISFACTORY

Senior Instructor Signature: _____ Date: _____

Drill and Ceremonies

Following are the most common terms referred to when teaching, demonstrating, and executing drill.

Alignment: Dress and cover

Cadence: The uniform step and rhythm in marching, that is the number of steps marched per minute.

Cover: Individuals aligning themselves directly behind the person in front while maintaining proper interval.

Distance: The space from front to rear between units. The distance between individuals in formation is 40 inches as measured from their chests to the backs of individuals directly in front of them.

Double-time: The rate of marching 180 steps (30 inches in length) per minute.

Dress: Alignment of elements placed side by side or in line while maintaining proper interval.

Element: The basic formation: that is, the smallest drill unit comprised of at least 3, but usually 8 to 12 individuals, one of whom is designated the element leader.

Flight: At least two, but no more than four elements.

Formation: An arrangement of units.

Guide: The cadet designated to regulate the direction and rate of March.

In Column (formation): The arrangement of units side by side with the guide and element leaders to the head (front).

In Line (formation): The arrangement of units one behind the other with the guide and leader to the extreme right flank.

Interval: The space between individuals placed side by side. Normal interval is arm's length, close interval is 4 inches.

Inverted Column (formation): The arrangement of units placed side by side with the guide and element leaders to the rear.

Inverted Line (formation): The arrangement of units one behind the other with the guide and element leaders to the extreme left flank.

Pace: A step of 24 inches. This is the length of a step in quick time.

Quick time: The rate of marching at 100 to 120 steps (12 or 24 inches in length) per minute.

Rank: A single line of persons placed side by side.

Slow Time: The rate of marching at 60 steps per minute (used in funeral ceremonies)

Step: The distance measured from heel to heel between the feet of an individual marching

Inspection Standards

Service Uniform

Flight cap – worn tilted towards the wearer’s right, with vertical crease at the center of the forehead in a straight with the nose, approximately 1-inch above the eyebrows. Hair may protrude from the front of the cap, but must not touch the eyebrows.

Short-Sleeve Blue blouse – must touch, or come with 1 –inch of the forearm when bent in a 90-degree angle. Do not press military creases into the blouse.

Tuck-in style blouses have a pointed collar with epaulets. The collar does not meet in the front, but is separated by a dark blue inverted V neck tab. These blouses must be tucked into the slacks and skirts.

Ribbons –center on the left side between the buttons and the seam, the bottom of the ribbons is even with the bottom of the nametag.

Name tag—centered on the right side even with or up to 1 ½ inches higher/lower the first exposed button.

Grade insignia is worn on the left and right collar, centered side to side and top to bottom. Bottom of torch points toward the point of the collar.

Skirt – straight style with or without belt loops, a pleat in the back, two pockets, a pleated front, skirts have a back zipper and lining attached inside. It is to be worn knee length (no higher than the top and no lower than the bottom of the knee)

Slacks – straight hanging, with two front pockets, a center fly front opening, and belt loops. The front of the slack rests on the shoe with a slight break in the crease. The back of the slacks will be approximately 7/8 of an inch longer than the front.

Belt – dark blue elastic, woven, or solid. Wear with skirts and slacks having belt loops. The belt must have a chrome-like finish. The tip of the belt must extend beyond the buckle facing the wearer’s right. No blue fabric mat show between the buckle and the belt tip.

Socks/Hosiery – Wear of hose with blue skirt is mandatory. You may wear hose or black socks when wearing slacks. Hose will be commercial sheer nylon. Colors may be either neutral or closely match the color of your skin. Patterned hose will not be worn.

Shoes – low quarters (oxfords) or pumps if authorized. They may be made of smooth or scotch- grained leather or man-made material and may be high gloss or patent leather if an upper classman. Heels of pumps should be suitable to the individual, but no higher than 2 ½ inches (measured from the inside of the sole of the shoe to the end of the heel lift). Do not wear shoes with platform soles, extra-thick soles or heels. They must be plain, black, commercial design without ornamentation.

Female Hair Standards

Hair will be styled to present a professional appearance.

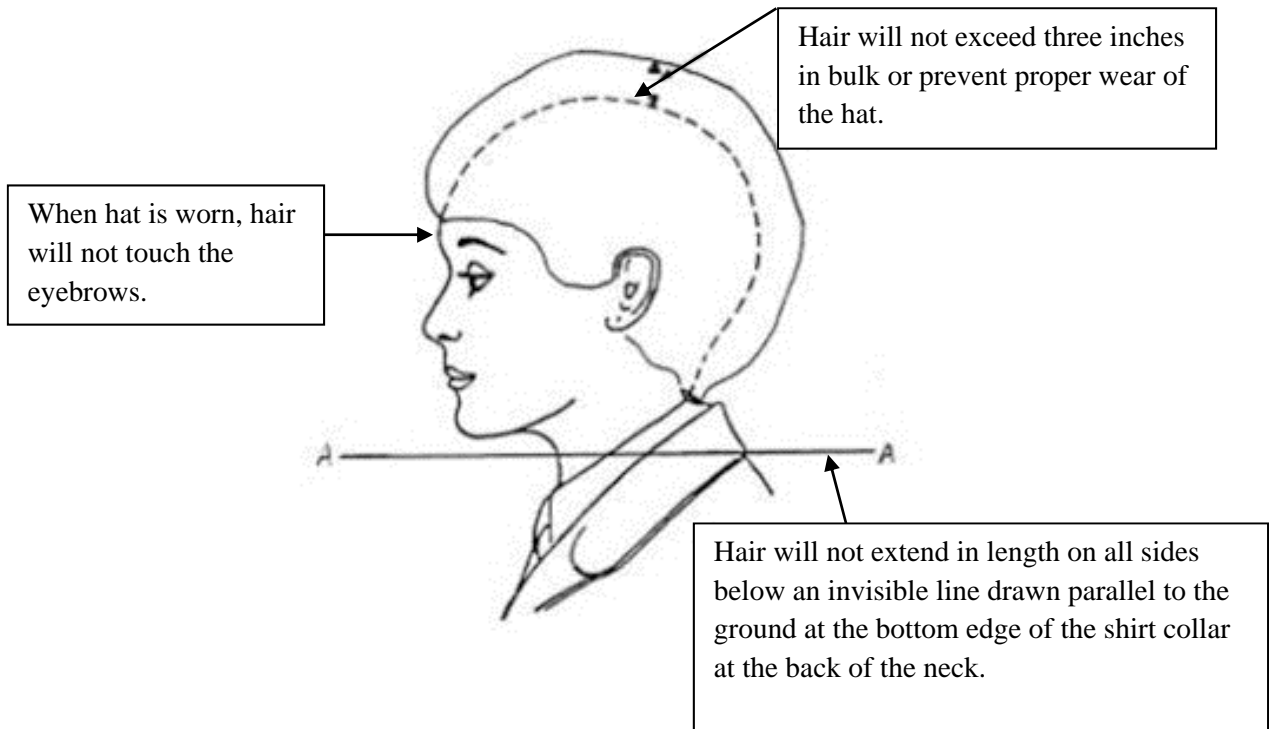

Male Hair Standards

Hair will have a tapered appearance on both sides and back. A tapered appearance is one that when viewed from any angle. Outline the individual's hair so that it conforms to the shape of the head, curving inward to the termination point.

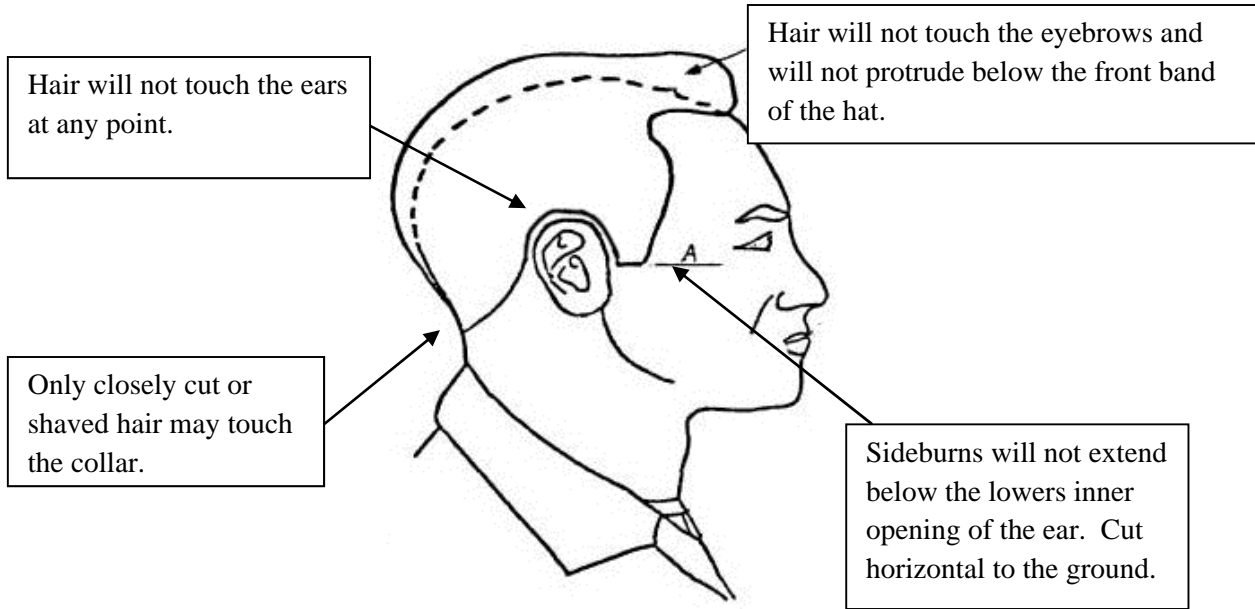

How to Tie a Tie

The Half-Windsor Knot



1. Start with wide end of the tie on your right and extending a foot below narrow end.
2. Cross wide end over narrow and turn back underneath.
3. Bring up and turn down through loop.
4. Pass wide end around front from left to right.
5. Then up through loop.
6. And down through knot in front. Tighten carefully and draw up to collar.

The Four-In-Hand Knot



1. Start with wide end of the tie on your right and extending a foot below narrow end.
2. Cross wide end over narrow and back underneath.
3. Continue around passing wide end across front of narrow once more.
4. Pass side end up through loop.
5. Holding front of knot loose with index finger, pass wide end down through loop in front.
6. Remove finger and tighten knot carefully. Draw up tight to collar by holding narrow end and sliding knot snug.

AFJROTC MERIT AND DEMERIT FORM
AIR FORCE JROTC - TEXAS-861st
Westwood High School
12400 Mellow Meadow Drive
Austin, Texas 78750
PH: (512) 464-4095
MERIT/DEMERIT CITATION FORM

TO: _____ of ___ Flight _____ DATE:
(Cadet's Name)

FROM:

1. Be advised that you have been awarded _____ merits /demerits (circle one) for the following reason:

2. If you desire to appeal this citation, state your reasons or mitigating circumstances below and submit to the Cadet Group Commander for their consideration. A further appeal can be made to the ASI or SASI.

_____ Appeal denied

3. Deputy Group Commander's action: Demerits removed _____
Demerits reduced to _____
Merits increased to _____

4. Approval of Merit / Demerit by SASI or ASI. Initials

ASI will approve merits/demerits forms for Leadership classes, Drill Team, Color Guard, and Saber Team.

SASI will approve merits/demerits forms for Aerospace Classes, Rocketry, Physical Fitness, and any not covered by above.

Fold and Tear on Line

TX-861st AFJROTC

MERIT/DEMERIT RECORD

TO: Deputy Group Commander

DATE:

FROM:

1. _____ of ___ Flight was awarded _____ merits/demerits for the following reason(s):

2. Approval of Merit / Demerit by SASI or ASI. Initials

3. Posted to cadet's record by _____ (date)

CURRICULUM PLAN FOR AFJROTC UNIT (BLOCK SCHEDULE)								
CADET YEAR	Fall 2014	Spring 2015	Fall 2015	Spring 2016	Fall 2016	Spring 2017	Fall 2017	Spring 2018
1	AS-100	AS-100	AS-100	AS-100	AS-100	AS-100	AS-100	AS-100
	LE-I (Units 1 & 2)	LE-I (Units 3 & 4) + Drill	LE-I (Units 1 & 2) + Drill	LE-I (Units 3 & 4) + Drill	LE-I (Units 1 & 2) + Drill	LE-I (Units 3 & 4) + Drill	LE-I (Units 1 & 2) + Drill	LE-I (Units 3 & 4) + Drill
2	AS-200 Science of Flight	AS-200	AS-300 Exploring Space	AS-300	AS-200 Science of Flight	AS-200	AS-300 Exploring Space	AS-300
	LE-II (Units 1 & 2) + Drill	LE-II (Units 3 & 4) + Drill	LE-III (Units 1 & 2) + Drill	LE-III (Units 3 & 4) + Drill	LE-II (Units 1 & 2) + Drill	LE-II (Units 3 & 4) + Drill	LE-III (Units 1 & 2) + Drill	LE-III (Units 3 & 4) + Drill
3	AS-200 Science of Flight	AS-200	AS-300 Exploring Space	AS-300	AS-200 Science of Flight	AS-200	AS-300 Exploring Space	AS-300
	LE-II (Units 1 & 2) + Drill	LE-II (Units 3 & 4) + Drill	LE-III (Units 1 & 2) + Drill	LE-III (Units 3 & 4) + Drill	LE-II (Units 1 & 2) + Drill	LE-II (Units 3 & 4) + Drill	LE-III (Units 1 & 2) + Drill	LE-III (Units 3 & 4) + Drill
4	AS-400 Management of Cadet Corps	AS-400	AS-400 Management of Cadet Corps	AS-400	AS-400 Management of Cadet Corps	AS-400	AS-400 Management of Cadet Corps	AS-400
	LE-IV (Units 1 & 2) + Drill	LE-IV (Units 3 & 4) + Drill	LE-IV (Units 1 & 2) + Drill	LE-IV (Units 3 & 4) + Drill	LE-IV (Units 1 & 2) + Drill	LE-IV (Units 3 & 4) + Drill	LE-IV (Units 1 & 2) + Drill	LE-IV (Units 3 & 4) + Drill
NOTES:								
1. Holm Center-provided materials used for all courses listed.								
2. LE and AS material is blended within each course, along with PT/Wellness being taught one day per week, to provide a 40% /40% /20% mix (2 days AS, 2 days LE, 1 day Wellness per week).								
3. 2 nd & 3 rd year Cadets are grouped together for LE/ AS 2 & 3 classes.								
4. 4 th year Cadets may also be taught: Management of the Cadet Corps; Survival; Global & Cultural Studies.								

TX 861st Organization Chart

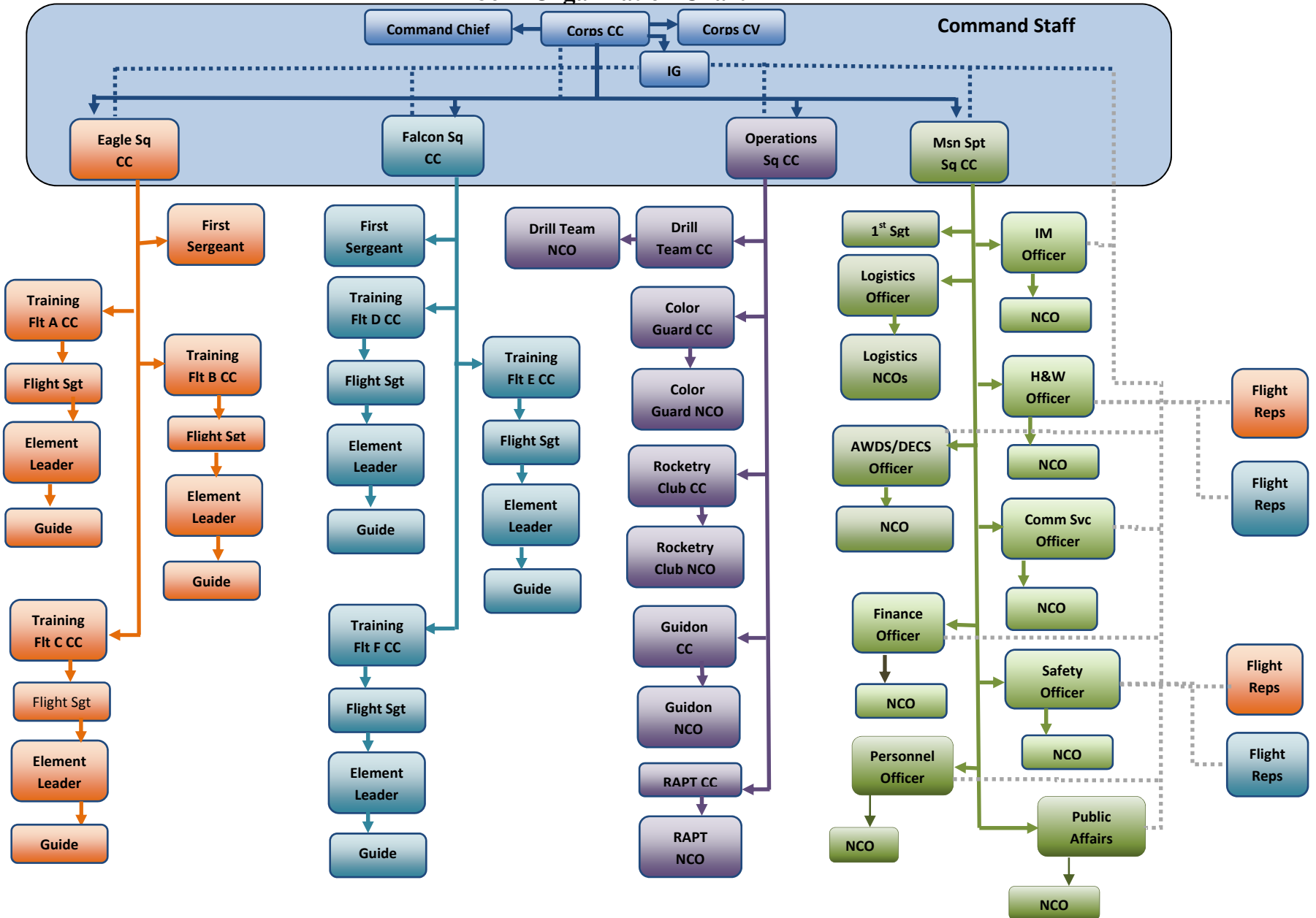

Command or Functional Authority

Coordination Authority





Mission:

**Develop citizens of character dedicated to serving their
nation and community**

Corps Values:

Integrity First

Service Before Self

Excellence in All We Do

Contact Information:

Westwood High School
AFJROTC, TX-861
12400 Mellow Meadows Dr.
Austin, Texas 78750

Phone: (512) 464-4095/6

Fax: (512) 464-4098

E-Mail: Phillip_Sandlin@roundrockisd.org

Mark_Janik@roundrockisd.org